

ABB Drives

User's Manual Absolute Encoder Interface FEN-11

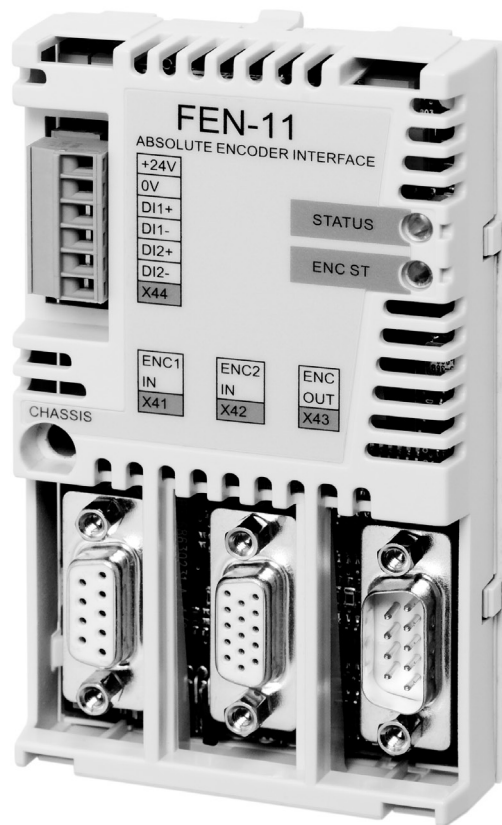

Absolute Encoder Interface
FEN-11

User's Manual

3AFE68784841 Rev B EN

EFFECTIVE: 16.11.2006

Safety instructions

Overview

This chapter states the general safety instructions that must be followed when installing and operating the FEN-11 Absolute Encoder Interface.

In addition to the safety instructions given below, read the complete safety instructions of the specific drive you are working on.

These warnings are intended for all who work on the drive. Ignoring the instructions can cause physical injury or death, or damage the equipment.

General safety instructions



Warning! All electrical installation and maintenance work on the drive should be carried out by qualified electricians only.

The drive and adjoining equipment must be properly earthed.

Do not attempt any work on a powered drive. After switching off the mains, always allow the intermediate circuit capacitors 5 minutes to discharge before working on the frequency converter, the motor or the motor cable. It is good practice to check (with a voltage indicating instrument) that the drive is in fact discharged before beginning work.

The motor cable terminals of the drive are at a dangerously high voltage when mains power is applied, regardless of motor operation.

There can be dangerous voltages inside the drive from external control circuits even when the drive mains power is shut off. Exercise appropriate care when working on the unit.

Table of Contents

Safety instructions	5
Overview	5
General safety instructions	5
 Table of Contents	 7
 Introduction	 9
Intended audience	9
Before you start	9
What this manual contains	9
 Overview	 11
Overview	11
The FEN-11 Absolute Encoder Interface	11
Compatibility	12
 Installation	 13
Setting the supply voltage	13
Mounting	14
Terminal designations	15
Encoder wiring	20
Phasing	27
Programming	28
 Fault tracing	 29
Diagnostic LEDs	29
 Technical data	 31

Introduction

Intended audience

The manual is intended for the people who are responsible for commissioning and using the FEN-11 Absolute Encoder Interface. The reader is expected to have a basic knowledge of electrical fundamentals, electrical wiring practices and how to operate the drive.

Before you start

It is assumed that the drive is installed and the drive power supply is switched off before starting the installation of the extension module. Ensure that all dangerous voltages connected from external control circuits to the inputs and outputs of the drive are switched off.

In addition to conventional installation tools, have the drive manuals available during the installation as they contain important information not included in this manual. The drive manuals are referred to at various points of this document.

What this manual contains

This manual contains information on the wiring, configuration and use of the FEN-11 Absolute Encoder Interface.

Safety instructions are featured in the first few pages of this manual.

Overview contains a short description of the FEN-11.

Installation contains instructions for hardware settings, mounting and cabling.

Fault tracing explains the LED indications of the FEN-11.

Technical data contains detailed technical information.

Overview

Overview

This chapter contains a short description of the FEN-11 Absolute Encoder Interface.

The FEN-11 Absolute Encoder Interface

The FEN-11 offers an interface for an absolute encoder and TTL encoder connection and a TTL encoder emulation output. It also supports two digital inputs for position latching.

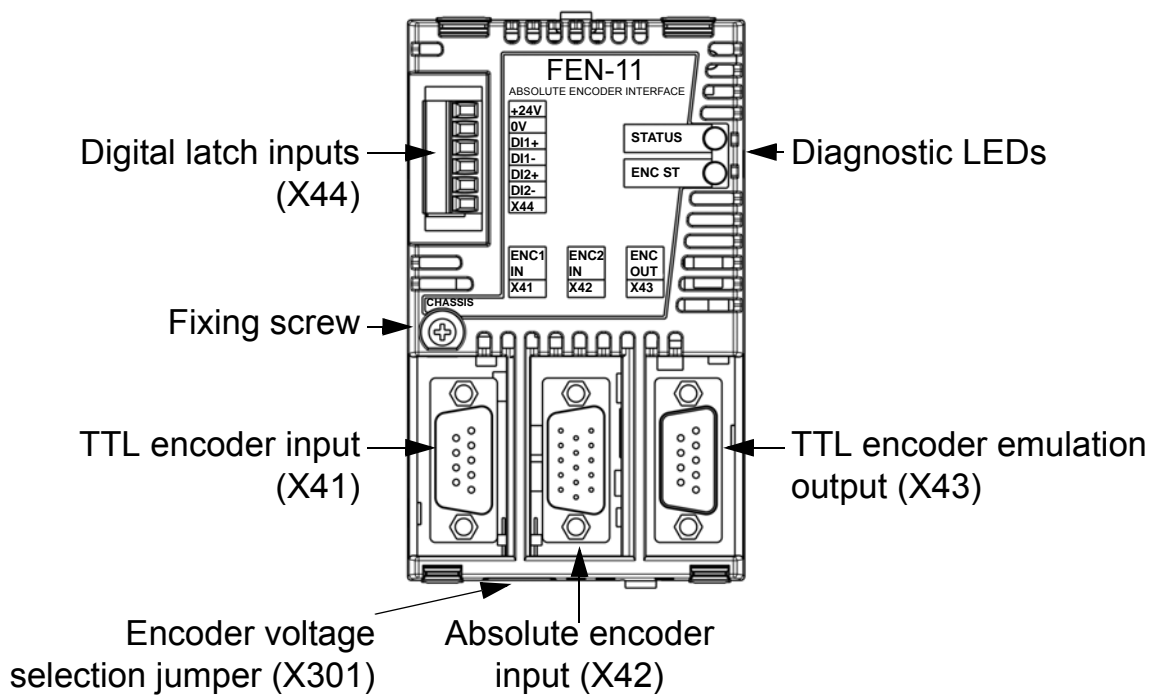

FEN-11 layout

Isolation areas

The following figure describes the different isolation areas of the module.

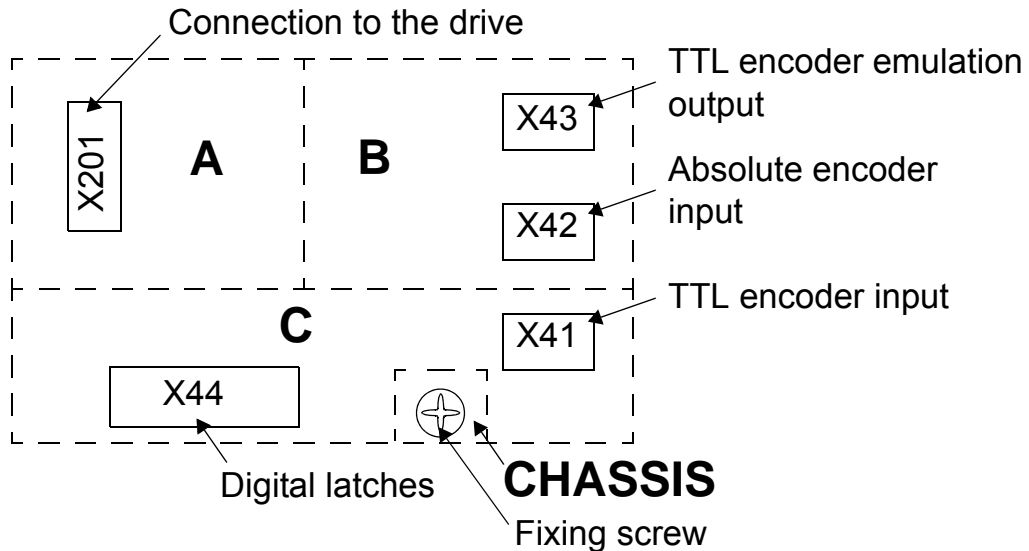

The shields of sockets X41 and X42 and plug X43 are connected to chassis. The fixing screw connects the chassis to ground.

Compatibility

FEN-11 is compatible with the following encoders.

Absolute Encoders

- Sin/Cos incremental encoder, 1...65535 pulses / rev, supports zero pulse and Sin/Cos commutation signals
- Endat 2.1
- Endat 2.2 with Sin/Cos signals (partially without Sin/Cos signals)
- Hiperface
- SSI with Sin/Cos signals (partially without Sin/Cos signals). Check compatibility.

TTL Encoders

- TTL incremental encoder, 1...65535 pulses / rev, supports zero pulse

Installation



Warning! Follow the safety instructions given in this guide and in the drive's hardware manual.

Setting the supply voltage



Warning! Selecting the wrong supply voltage may damage or break the encoder.

A selectable supply voltage is provided for the absolute encoder's and the TTL encoder's input. A +5.5 V or a +24 V voltage for a TTL encoder and a +5.5 V or a +8 V voltage for an absolute encoder can be selected by vertically mounted jumpers as described by the following figure.

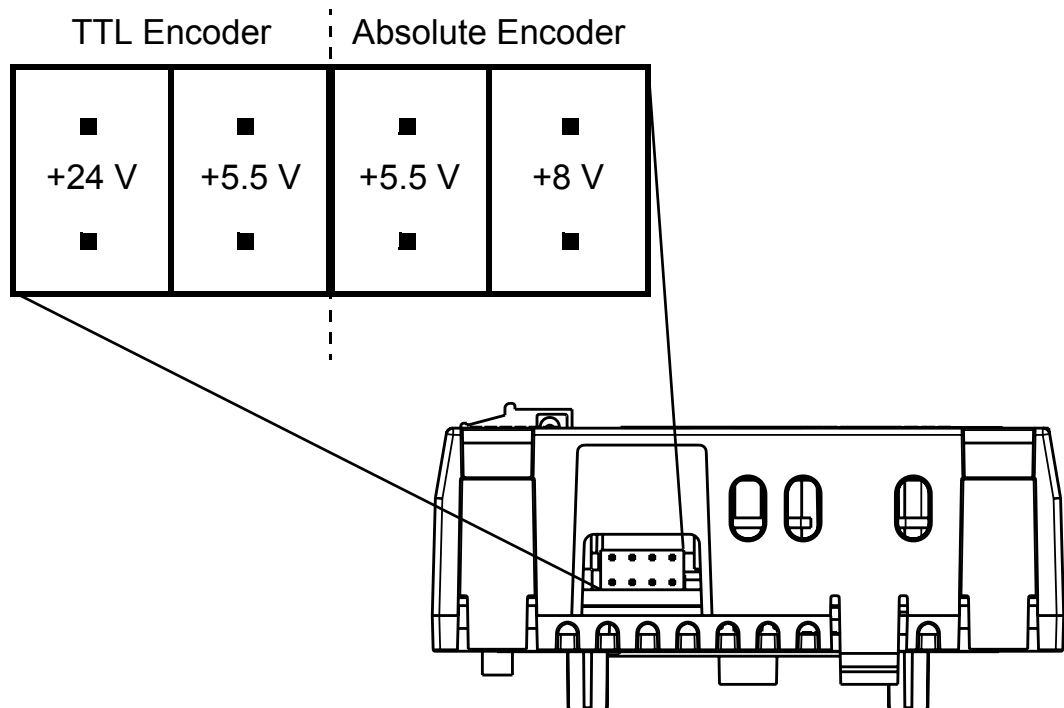

Supply voltage jumpers

Note: If an external power supply is used, the appropriate jumper must be removed.

Note: If another FEN interface's TTL emulation output is connected to TTL input, the appropriate jumper must be removed.

Mounting



Warning! Before installation, switch off the drive power supply. Wait for five minutes to ensure that the capacitor bank of the drive is discharged. Switch off all dangerous voltages connected from external control circuits to the inputs and outputs of the drive.

Note: Before mounting the module, set the supply voltage jumpers as described above.

The FEN-11 is to be inserted into the option slot of the drive. See the drive hardware manual for more information.

The module is held in place with plastic retaining clips and one screw. The screw also provides the earthing of the cable shields connected to the module and interconnects the GND signals of the module and the drive.

On installation of the module, the signal and power connection to the drive is automatically made through a 20-pin connector.

Mounting procedure:

- Insert the module carefully into the option slot until the retaining clips lock the module into position.
- Fasten the screw (included) to the stand-off.

Note: Correct installation of the screw is essential for fulfilling the EMC requirements and for proper operation of the module.

Terminal designations

Abbreviations

AI	Analog in
DI	Digital in
DIO	Digital in and out
DO	Digital out
PO	Power out

TTL encoder input (X41)

Pin	Name	Direction	Description
1	A+	DI	Channel A+
2	B+	DI	Channel B+
3	Z+	DI	Channel Z+
4	COM_C	-	Common
5	VCC_ENC_1	PO	Supply voltage (5.5 V or 24 V)
6	A-	DI	Channel A-
7	B-	DI	Channel B-
8	Z-	DI	Channel Z-
9	COM_C	-	Common
-	Shield	-	Shield

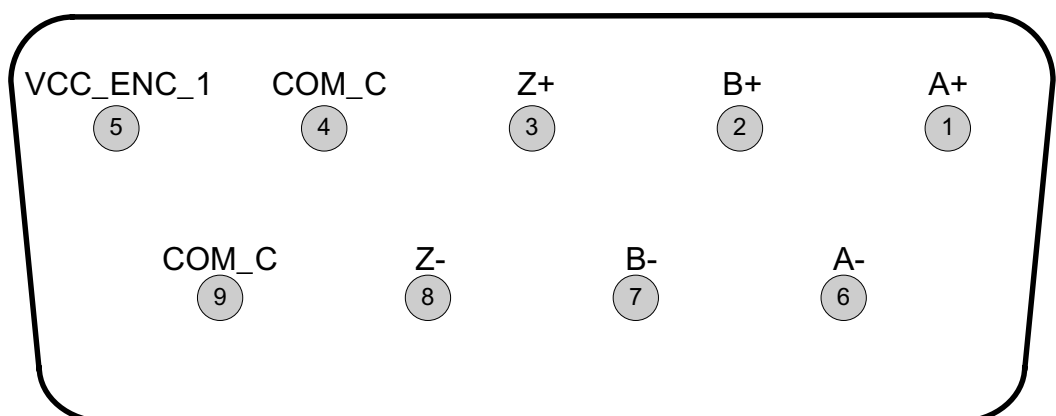

TTL encoder input (X41) pin order

Absolute encoder input (X42)

Pin	Name	Optional Function	Direction	Description
1	SIN-		AI	Sine ref.
2	COS-		AI	Cosine ref.
3	PTC/KTY		AI	Temperature sensor
4	PTC/KTY_0V		AI	Common, 0V, reserved for temperature sensor
5	CLOCK	SIN_CM+	DO/AI	Clock or sine commutation signal
6	SIN+		AI	Sine signal
7	COS+		AI	Cosine signal
8	COM_B		-	Common, 0V
9	NC*	COS_CM+	AI	Cosine commutation signal
10	\CLOCK	SIN_CM-	DO/AI	Inverted clock or sine commutation signal, inverted
11	VCC_ENC_2		PO	Supply voltage (5.5 V or 8 V)
12	COM_B		-	Common, 0V
13	NC*	COS_CM-	AI	Cosine commutation signal, inverted
14	DATA	Z+	DIO/DI	Data line or Marker pulser
15	\DATA	Z-	DIO/DI	Inverted data line or Marker pulse, inverted
-	Shield		-	Shield

*NC = Not connected

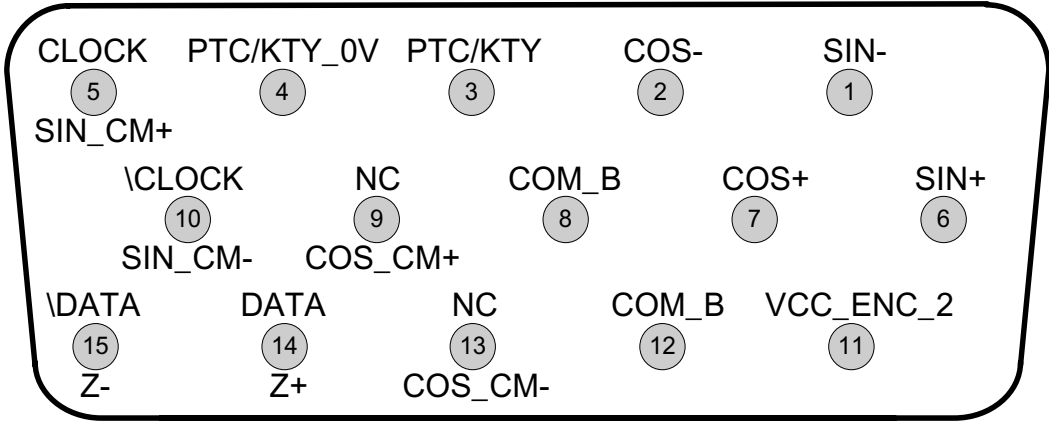

X = Primary function
 Y = Optional function

Absolute encoder input (X42) general pin order

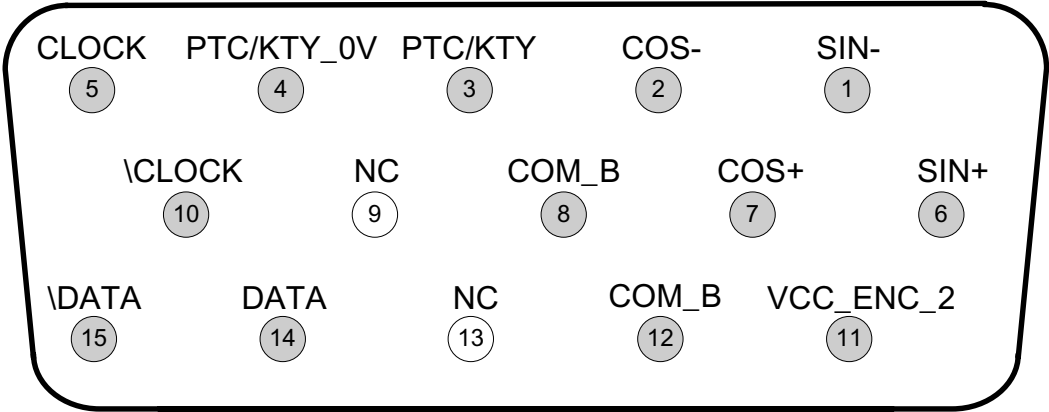

Pin order with EnDat 2.1 and 2.2 absolute encoder

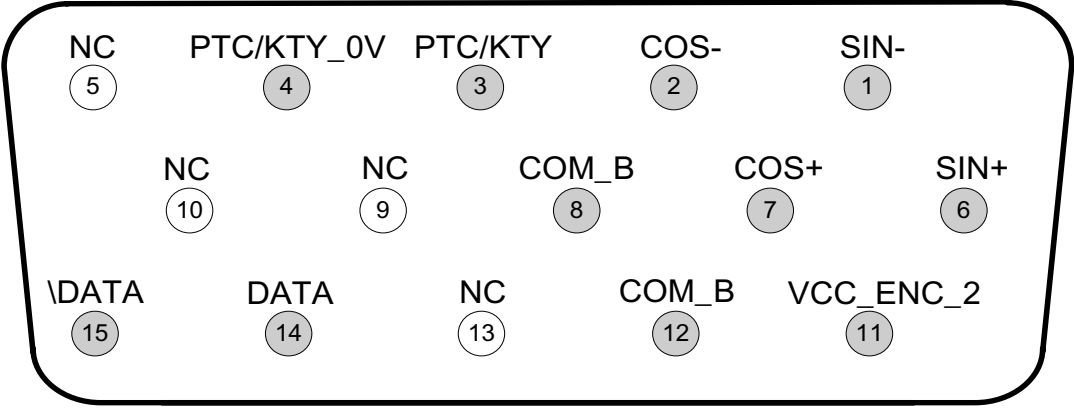

Pin order with HIPERFACE absolute encoders

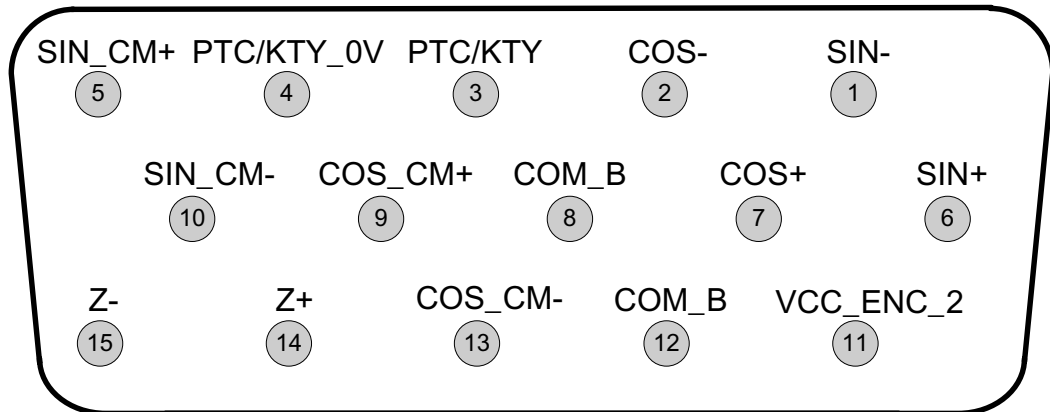

Pin order with SIN/COS encoders with/without sin/cos commutation pulses and Z mark pulses

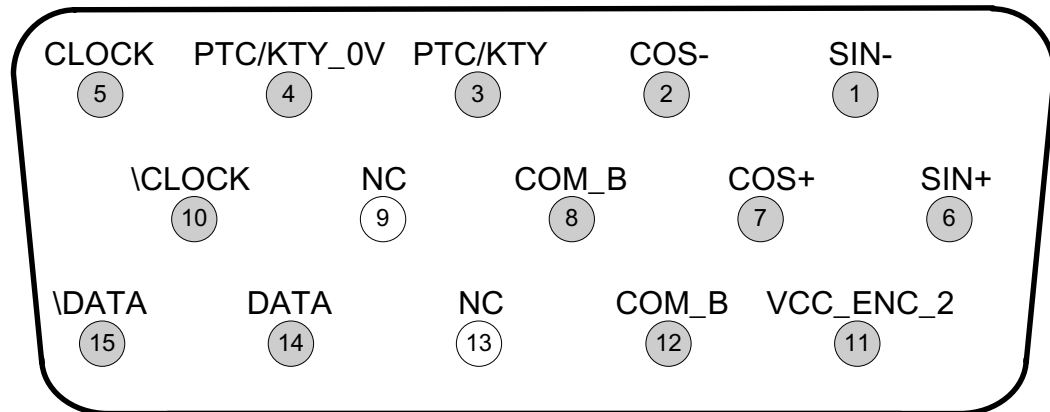

Pin order with SSI absolute encoders

TTL encoder emulation output (X43)

Pin	Name	Direction	Description
1	EM_A+	DO	Channel A+
2	EM_B+	DO	Channel B+
3	EM_Z+	DO	Channel Z+
4	COM_B	-	Common
5	COM_B	-	Common
6	EM_A-	DO	Channel A-
7	EM_B-	DO	Channel B-
8	EM_Z-	DO	Channel Z-
9	COM_B	-	Common
-	Shield	-	Shield

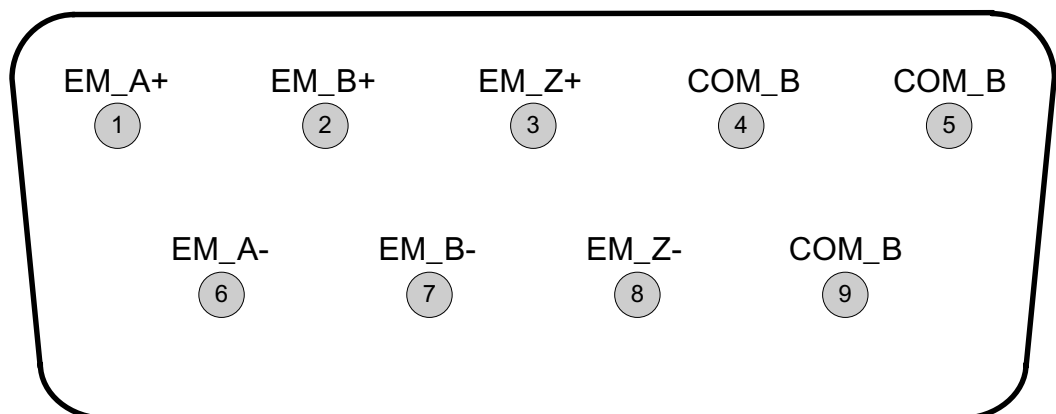
*TTL encoder emulation output (X43) pin order*

Digital inputs for position latching (X44)

Pin	Name	Direction	Description
1	+24V_C	PO	Supply voltage
2	COM_C	-	Common
3	DI_1+	DI	Latch signal 1
4	DI_1-	-	Latch signal 1 return
5	DI_2+	DI	Latch signal 2
6	DI_2-	-	Latch signal 2 return

Encoder wiring

The encoders should be connected to the FEN-11 with a shielded instrumentation cable, preferably with twisted pairs. See also the encoder manual for additional requirements. To prevent the encoder inputs from being disturbed, the cable shield must be connected to the chassis. The connection is made automatically through the metal hood of the plug, if the cables are connected through the cable clamp of the plug.

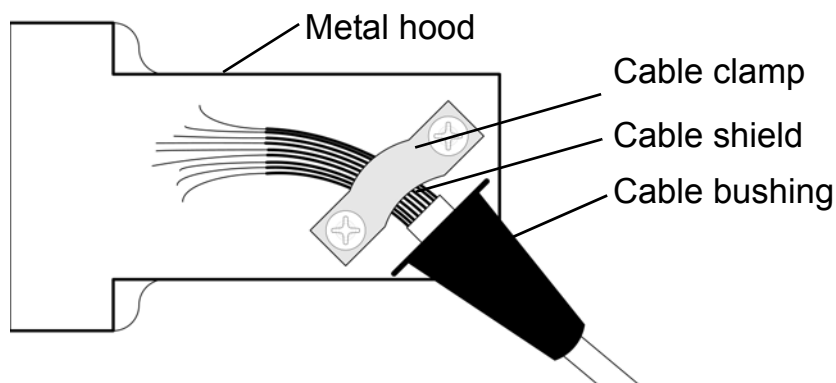

Cable shield connected to the cable clamp

Note: Do not route the encoder cables parallel to power (e.g. motor) cables.

Tightening torque is 0.3 Nm (2.7 lbf-in.) for the plugs.

The allocation of cable pairs is described for each connector in the following tables.

TTL encoder input (X41)

The cable should have minimum 4 cable pairs. A fifth cable pair shared between Vcc an 0V pins allows for a longer cable.

Cable pair number	Signals name	X41 connecting plug pin number (9-pins)	Notes
1	A+	1	
	A-	6	
2	B+	2	
	B-	7	
3	Z+	3	
	Z-	8	
4	VCC_ENC_1	5	
	COM_C	9	
5	VCC_ENC_1*	5*	OPTIONAL
	COM_C	4	OPTIONAL

* Two wires soldered to the same pin.

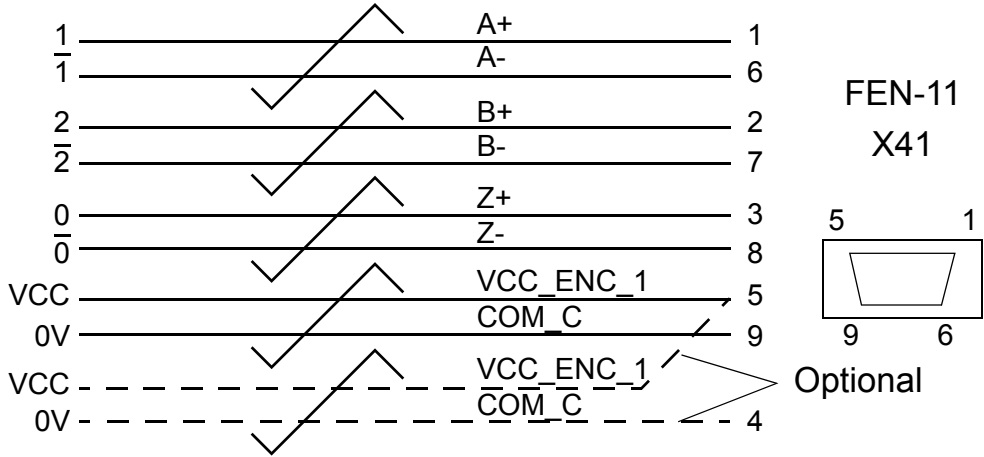

TTL encoder input (X41)

Absolute encoder input (X42)

The cable should have minimum 7 cable pairs. An extra pair could be soldered to supply voltage and 0V pins.

Cable pair number	Signals name		X42 connecting plug pin number (15-pins)	Notes
1	SIN+		6	
	SIN-		1	
2	COS+		7	
	COS-		2	
3	CLOCK	SIN_CM+	5	
	\CLOCK	SIN_CM-	10	
4	-	COS_CM+	9	
	-	COS_CM-	13	
5	DATA	Z+	14	
	\DATA	Z-	15	
6	PTC/KTY-84		3	Temperature sensor
	COM_B		4	Temperature sensor
7	VCC_ENC_2		11	
	COM_B		12	
8	VCC_ENC_2*		11*	OPTIONAL
	COM_B		8	OPTIONAL

* Two wires soldered to the same pin.

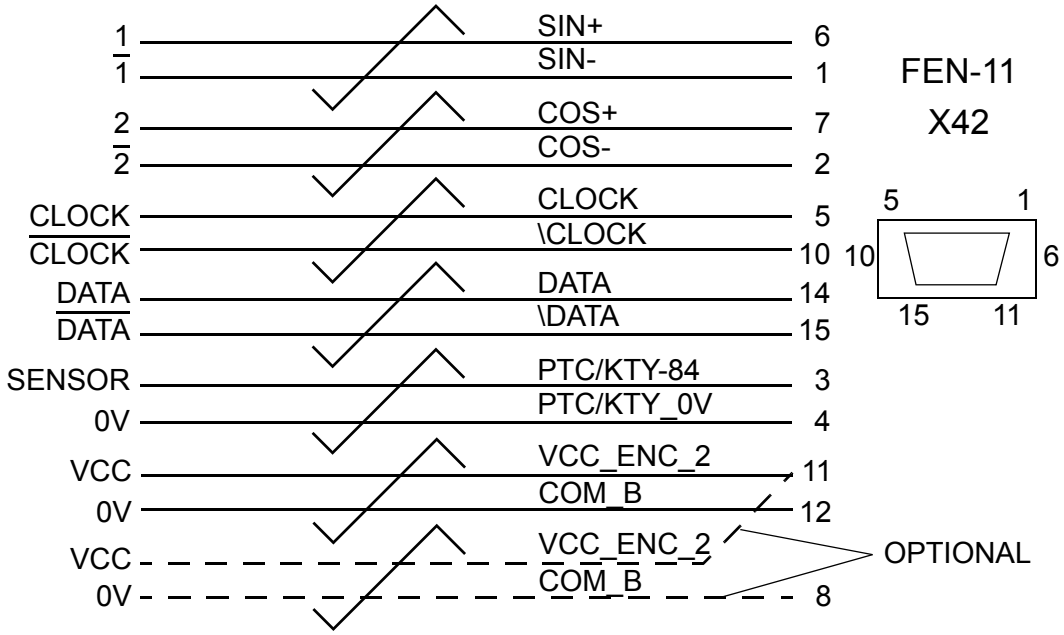

EnDat 2.1 and EnDat 2.2 absolute encoders

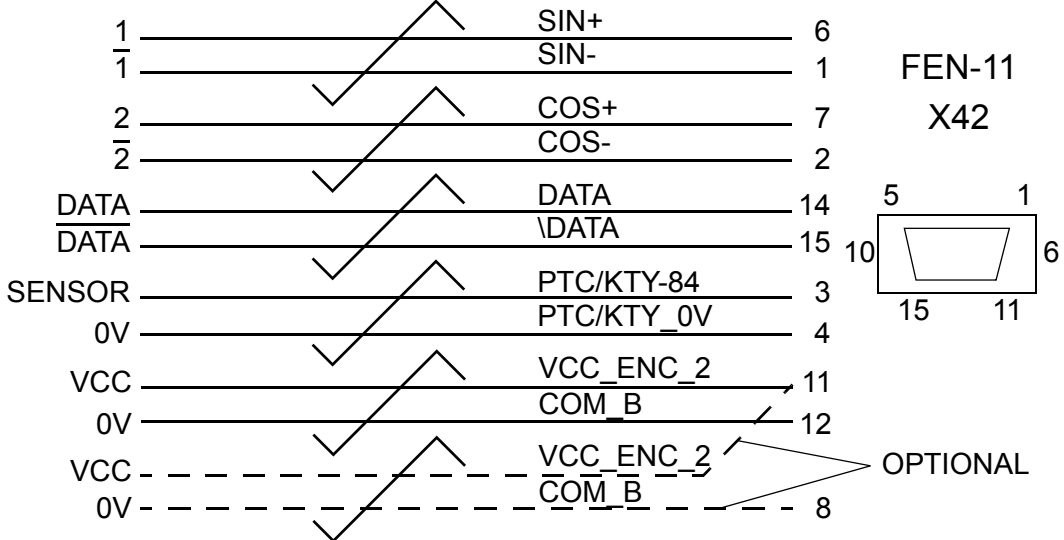

HIPERFACE absolute encoders

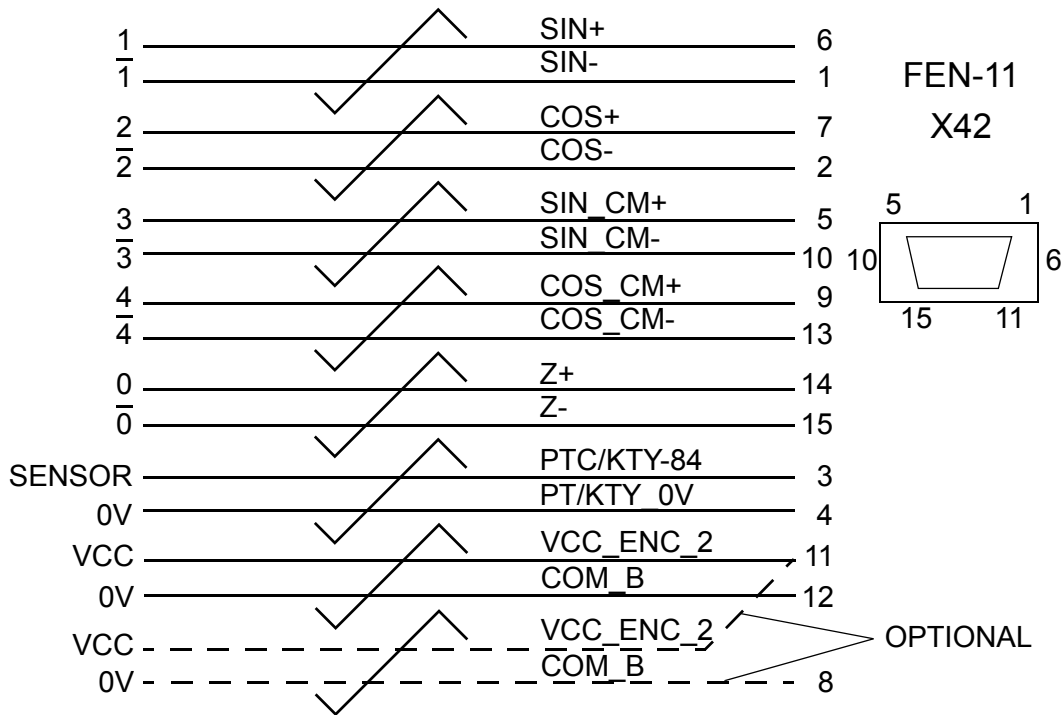

SIN/COS encoders with/without sin/cos commutation pulses and Z mark pulses

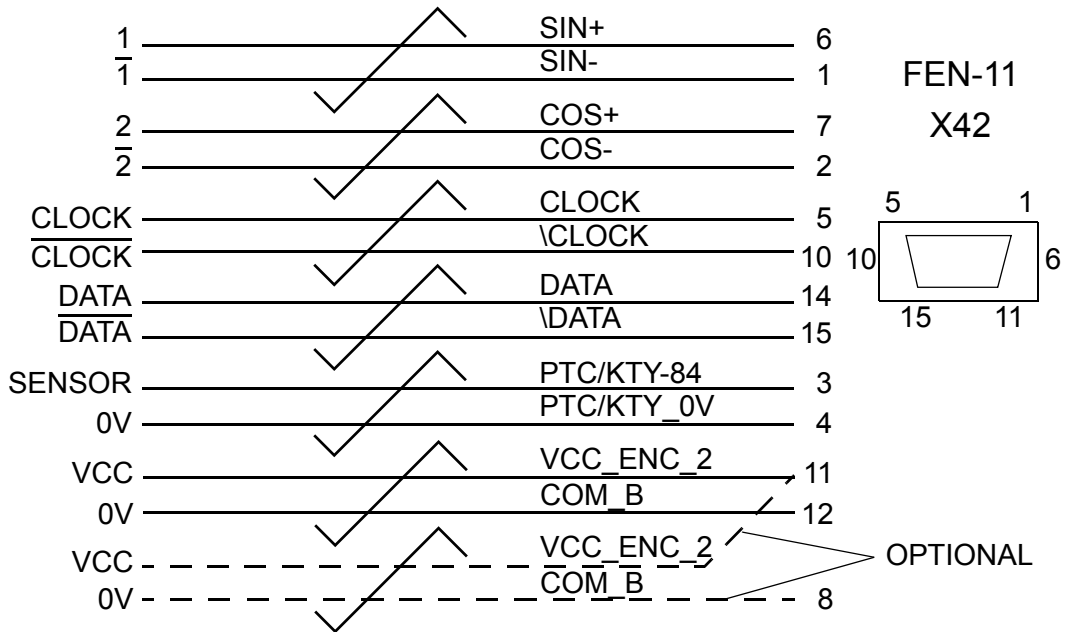

SSI absolute encoders

TTL encoder emulation output (X43)

The cable should have 4 cable pairs. An extra pair for 0V pins can also be connected.

Cable pair number	Signals name	X43 connecting socket pin number (9-pins)	Notes
1	EM_A+	1	
	EM_A-	6	
2	EM_B+	2	
	EM_B-	7	
3	EM_Z+	3	
	EM_Z-	8	
4	COM_B	4	
	COM_B	9	
5	COM_B	5	OPTIONAL
	COM_B*	9*	OPTIONAL

*Two wires soldered to the same pin.

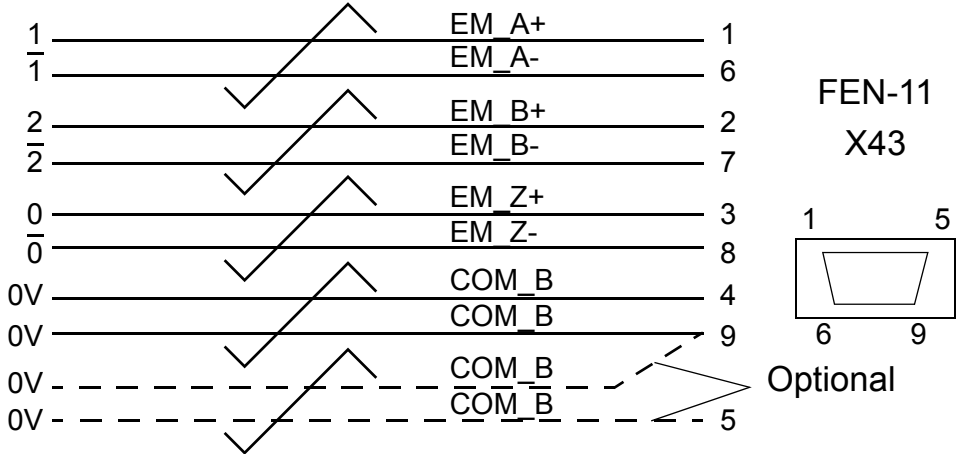

TTL encoder emulation output (X43)

Digital inputs for position latching (X44)

Cable pair number	Signals name	X44 connecting header pin number (6-pins)	Notes
1	+24V_C	1	
	COM_C	2	
2	DI_1+	3	
	DI_1-	4	
3	DI_2+	5	
	DI_2-	6	

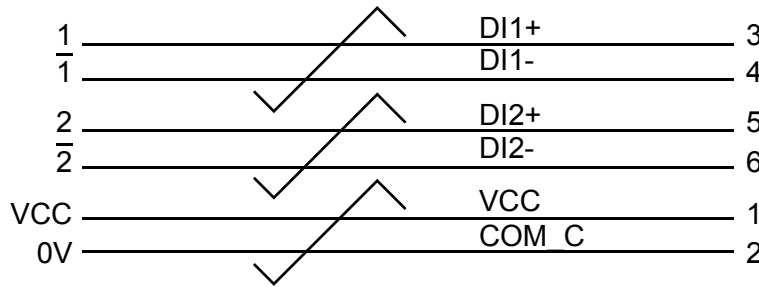

FEN-11
X44

Digital inputs for position latching (X44)

Phasing

When the TTL encoder is connected correctly, running the drive in the *Forward* direction should produce a positive encoder feedback.

On incremental encoders, the two output channels, usually marked 1 and 2 or A and B, are 90° (electrical) apart from each other. When rotated clockwise, most encoders – but not all – have channel 1 leading channel 2 as illustrated below. Determine the leading channel by referring to the encoder documentation or by measuring with an oscilloscope.

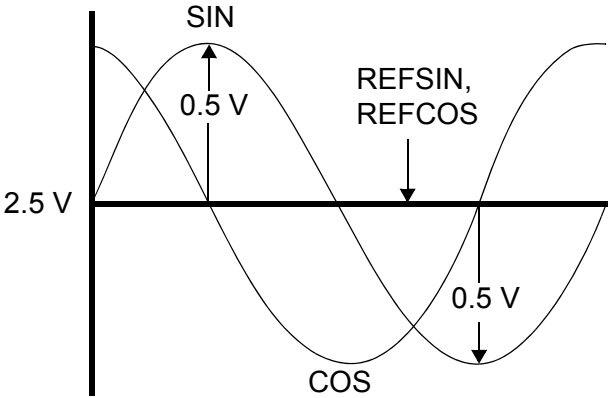
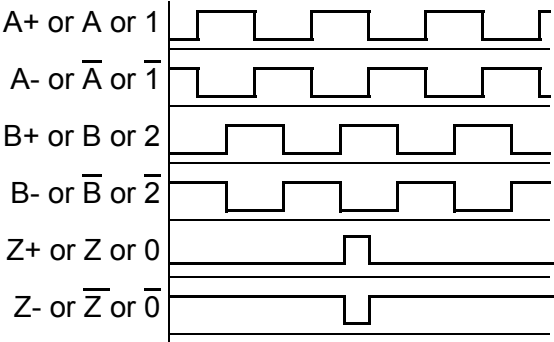

The encoder output channel that leads when the drive runs *Forward* should be connected to FEN-11 input A, the output channel that trails to FEN-11 input B.

The zero reference output channel (usually marked 0, N or Z) needs to be connected in positioning applications only.

Programming

The FEN-11 is programmed through drive parameters. These parameters must be checked and adjusted according to the encoder data sheet. For further information, see the drive *Firmware Manual*.

Fault tracing

Diagnostic LEDs

The FEN-11 is equipped with two diagnostic LEDs. The STATUS LED describes the status of the FEN-11 and the ENC ST LED the status of the encoders. Description of the LED signals is presented below.

	Colour	Description
STATUS LED	Green	OK
	Orange	Not initialized or communication fault to control unit
	Red	Not in use
ENC ST LED	Green	Encoder(s) OK
	Red	ENC1 (TTL encoder, X41) fault
	Orange	ENC2 (absolute encoder, X42) fault
	Red / orange swapping	ENC1 fault & ENC 2 fault
	Red flashing	ENC1 warning
	Orange flashing	ENC2 warning

Technical data

Dimensions:

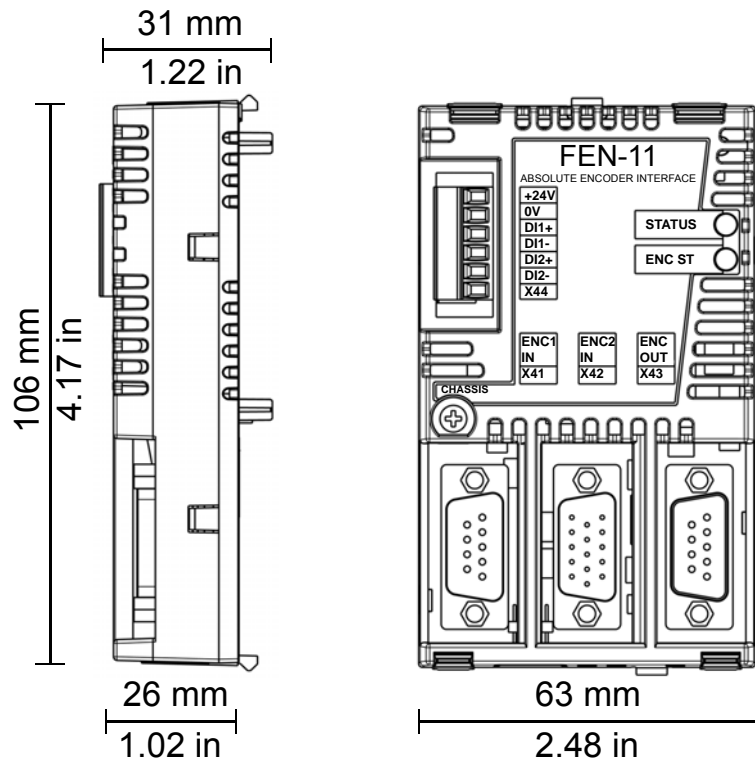

General

- Max. power consumption: 350 mA at 24 V
- Degree of protection: IP20
- Ambient conditions: The applicable ambient conditions specified for the drive in its *Hardware Manual* are in effect

Connectors:

- 20-pin socket
- 9-pin D-sub socket
- 15-pin D-sub socket
- 9-pin D-sub plug
- 6-pin header.

TTL encoder input (X41)

- Output voltages:
 - +5.5 V DC +15%, -5%, 180 mA
 - +24 V DC \pm 15%, 150 mA together with digital inputs
 - +5.5 V and +24 V combined maximum power is 3.6 W
- CH A, CH B, CH Z: RS-422/485, differential, 500 kHz (max)
- Maximum cable length:
 - 30 m with a 5 V encoder (0.5 mm² cable)
 - 60 m with a 5 V encoder (two parallel 0.5 mm² cables for power supply)
 - 100 m with a 10...30 V TTL incremental encoder
- Performance:
 - Speed range: -32768...32767 rpm
 - Speed resolution: 0.04 RPM (24 bits)
 - Position resolution: 16 M / rev (24 bits)
 - Position accuracy: 4x pulse count / rev
- Isolated together with digital inputs

Absolute encoder input (X42)

- Output voltages:
 - +5.5 V DC \pm 2%, 250 mA
 - Output voltage 2: +8 V DC +20%, -5%, 130 mA
- KTY84 or PTC thermistor input
- Sin & cos signals: 1 Vp-p (nom), 1.2 Vp-p (max), 500 kHz (max)
- Serial link: signals according to RS-422/485
- Maximum cable length:
 - 25 m (0.5 mm² cable)
 - 50 m (two parallel 0.5 mm² cables for power supply)
 - 75 m with an external power source for the encoder

- Performance
 - Speed range: -32768...32767 rpm
 - Speed resolution: 0.04 RPM (24 bits)
 - Position resolution: 16 M / rev (24 bits)
- Isolated together with TTL encoder emulation output

TTL encoder emulation output (X43)

- Supports emulations of TTL incremental encoder, 1...65535 pulses / rev, zero pulse
- CH A, CH B, CH Z: RS-422/485, 500 kHz (max)
- Maximum cable length: 100 m
- Performance
 - Speed range: -32768...32767 rpm
 - Position resolution: 4x pulse count / rev
- Isolated together with absolute encoder input

Digital inputs for position latch (X44)

- Output voltage: +24 V DC $\pm 15\%$, short-circuit proof
- Signal levels: $< 5\text{ V} = 0$, $> 15\text{ V} = 1$
- Isolated together with TTL encoder input



ABB Oy

AC Drives

P.O. Box 184

FIN-00381 HELSINKI

FINLAND

Telephone +358 10 22 11

Telefax +358 10 22 22681

Internet <http://www.abb.com>**ABB Inc.**

Automation Technologies

Drives & Motors

16250 West Glendale Drive

New Berlin, WI 53151

USA

Telephone 262 785-3200

800-HELP-365

Telefax 262 780-5135

**ABB Beijing Drive Systems
Co. Ltd.**

No. 1, Block D,

A-10 Jiuxianqiao Beilu

Chaoyang District

Beijing, P.R. China, 100015

Telephone +86 10 5821 7788

Fax +86 10 5821 7618

3AFE68784841 Rev B EN
EFFECTIVE: 16.11.2006