

ABB Drives

User's Manual Resolver Interface FEN-21

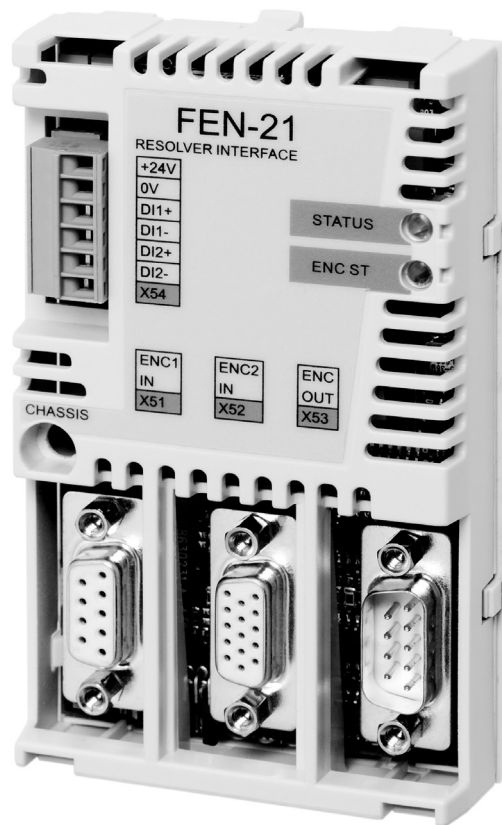

Resolver Interface
FEN-21

User's Manual

3AFE68784859 Rev B EN

EFFECTIVE: 16.11.2006

Safety instructions

Overview

This chapter states the general safety instructions that must be followed when installing and operating the FEN-21 Resolver Interface.

In addition to the safety instructions given below, read the complete safety instructions of the specific drive you are working on.

These warnings are intended for all who work on the drive. Ignoring the instructions can cause physical injury or death, or damage the equipment.

General safety instructions



Warning! All electrical installation and maintenance work on the drive should be carried out by qualified electricians only.

The drive and adjoining equipment must be properly earthed.

Do not attempt any work on a powered drive. After switching off the mains, always allow the intermediate circuit capacitors 5 minutes to discharge before working on the frequency converter, the motor or the motor cable. It is good practice to check (with a voltage indicating instrument) that the drive is in fact discharged before beginning work.

The motor cable terminals of the drive are at a dangerously high voltage when mains power is applied, regardless of motor operation.

There can be dangerous voltages inside the drive from external control circuits even when the drive mains power is shut off. Exercise appropriate care when working on the unit.

Table of Contents

Safety instructions	5
Overview	5
General safety instructions	5
 Table of Contents	 7
 Introduction	 9
Intended audience	9
Before you start	9
What this manual contains	9
 Overview	 11
Overview	11
The FEN-21 Resolver Interface	11
Compatibility	12
 Installation	 13
Setting the supply voltage	13
Mounting	14
Terminal designations	15
Encoder wiring	19
Phasing	24
Programming	25
 Fault tracing	 27
Diagnostic LEDs	27
 Technical data	 29

Introduction

Intended audience

The manual is intended for the people who are responsible for commissioning and using an FEN-21 Resolver Interface. The reader is expected to have a basic knowledge of electrical fundamentals, electrical wiring practices and how to operate the drive.

Before you start

It is assumed that the drive is installed and the drive power supply is switched off before starting the installation of the extension module. Ensure that all dangerous voltages connected from external control circuits to the inputs and outputs of the drive are switched off.

In addition to conventional installation tools, have the drive manuals available during the installation as they contain important information not included in this manual. The drive manuals are referred to at various points of this document.

What this manual contains

This manual contains information on the wiring, configuration and use of the FEN-21 Resolver Interface.

Safety instructions are featured in the first few pages of this manual.

Overview contains a short description of the FEN-21.

Installation contains instructions for hardware settings, mounting and cabling.

Fault tracing explains the LED indications of the FEN-21.

Technical data contains detailed technical information.

Overview

Overview

This chapter contains a short description of the FEN-21 Resolver Interface and a delivery checklist.

The FEN-21 Resolver Interface

The FEN-21 offers an interface for a resolver and TTL encoder connection and a TTL encoder emulation output. It also supports two digital inputs for position latching.

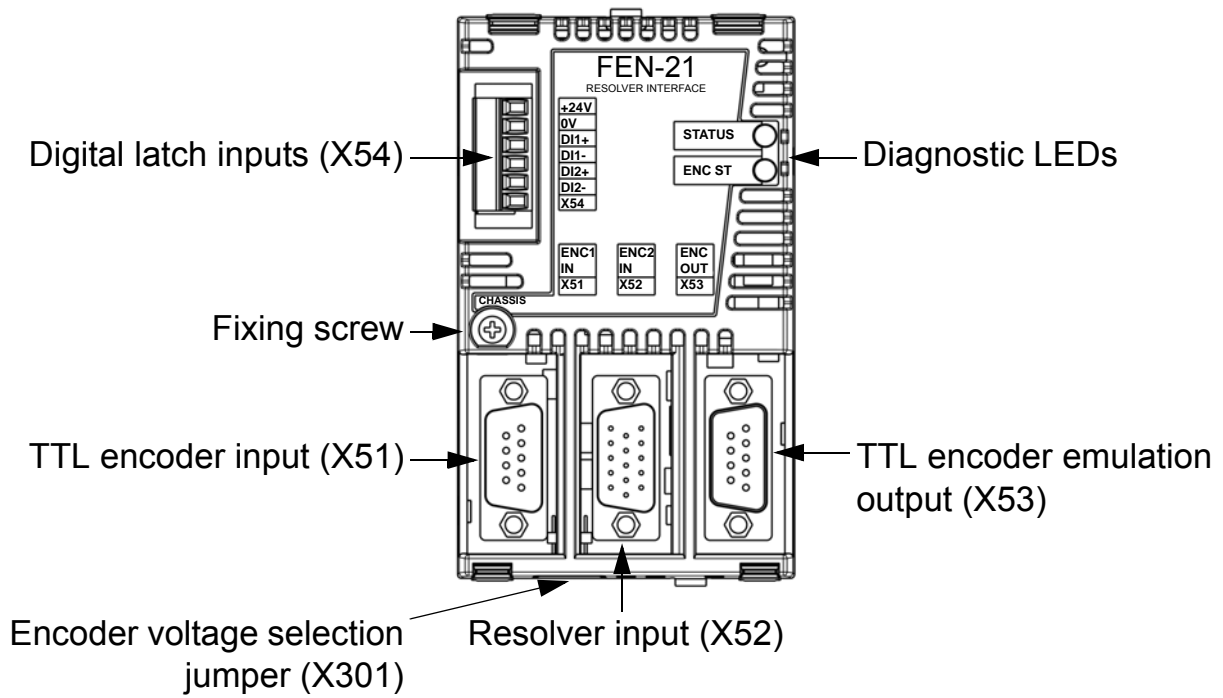

FEN-21 layout

Isolation areas

The following figure describes the different isolation areas of the module.

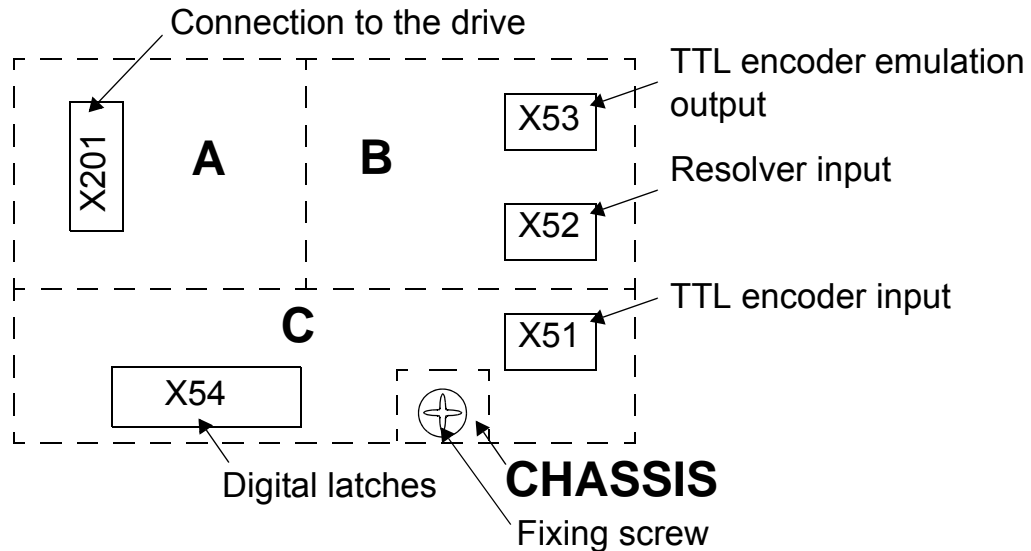

The shields of sockets X51 and X52 and plug X53 are connected to chassis. The fixing screw connects the chassis to ground.

Compatibility

Resolvers

The FEN-21 is compatible with resolvers, which are excited by sinusoidal voltage (to the rotor winding), and which generate sine and cosine signals proportional to the rotor angle (to stator windings). Amplitude and frequency of the excitation signal can be adjusted in range $4...12 V_{rms}$, $1...20$ kHz. Transformation ratio of the resolver must be such that sine and cosine signals remains in range $2...7 V_{rms}$.

TTL Encoders

The FEN-21 is compatible with TTL incremental encoders with $1...65535$ pulses / rev and it supports zero pulse.

Installation



Warning! Follow the safety instructions given in this guide and in the drive hardware manual.

Setting the supply voltage



Warning! Selecting the wrong supply voltage may damage or break the encoder.

A selectable supply voltage is provided for the TTL encoders input. A +5.5 V or a +24 V voltage for a TTL encoder can be selected by a jumper as described by the following figure.

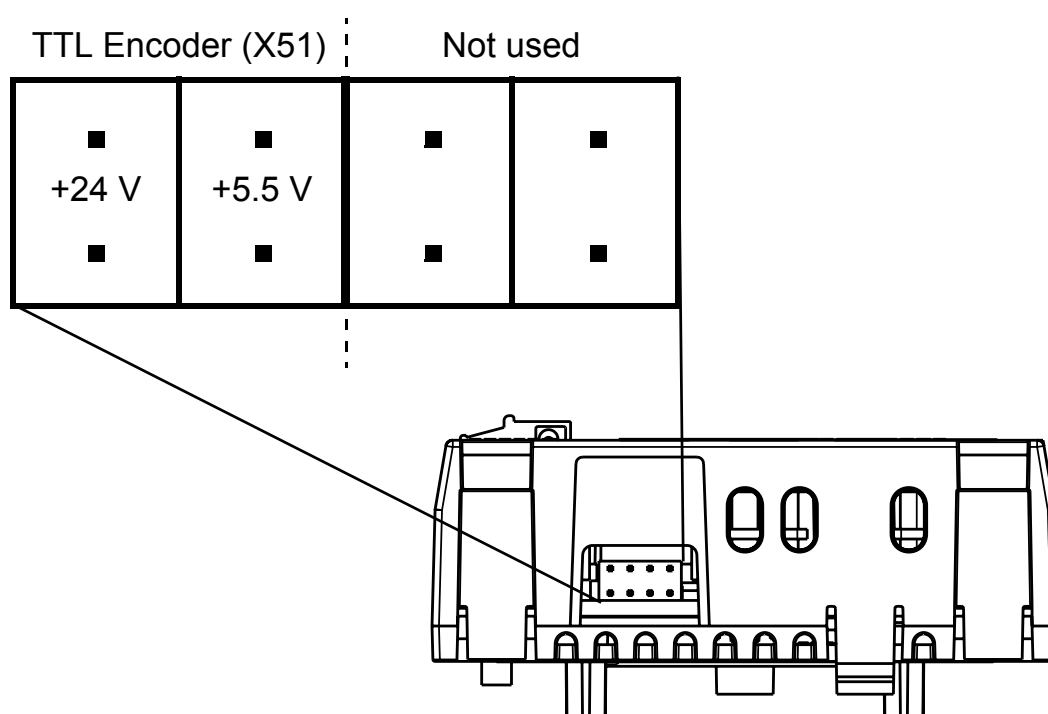

Note: If an external power supply is used, the appropriate jumper must be removed.

Note: If another FEN interface's TTL emulation output is connected to TTL input, the appropriate jumper must be removed.

Mounting



Warning! Before installation, switch off the drive power supply. Wait for five minutes to ensure that the capacitor bank of the drive is discharged. Switch off all dangerous voltages connected from external control circuits to the inputs and outputs of the drive.

Note: Before mounting the module, set the supply voltage jumper as described above.

The FEN-21 is to be inserted into the option slot of the drive. See the drive hardware manual for more information.

The module is held in place with plastic retaining clips and one screw. The screw also provides the earthing of the cable shields connected to the module and interconnects the GND signals of the module and the drive.

On installation of the module, the signal and power connection to the drive is automatically made through a 20-pin connector.

Mounting procedure:

- Insert the module carefully into the option slot until the retaining clips lock the module into position.
 - Fasten the screw (included) to the stand-off.
-

Note: Correct installation of the screw is essential for fulfilling the EMC requirements and for proper operation of the module.

Terminal designations

Abbreviations

AI	Analog in
AO	Analog out
DI	Digital in
DO	Digital out
PO	Power out

TTL encoder input (X51)

Pin	Name	Direction	Description
1	A+	DI	Channel A+
2	B+	DI	Channel B+
3	Z+	DI	Channel Z+
4	COM_C	-	Common
5	VCC_ENC_1	PO	Supply voltage
6	A-	DI	Channel A-
7	B-	DI	Channel B-
8	Z-	DI	Channel Z-
9	COM_C	-	Common
-	Shield	-	Shield

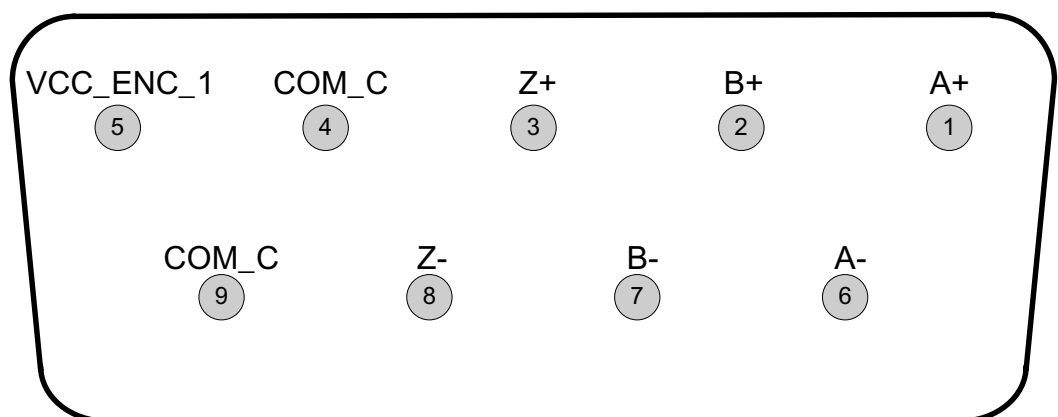

TTL input (X51) pin order

Resolver input

Pin	Name	Direction	Description
1	SIN-	AI	Inverted sine signal
2	COS-	AI	Inverted cosine signal
3	PTC/KTY	AI	Temperature sensor
4	COM_B	-	Common, reserved for temperature sensor
5	EXCITATION+	AO	Excitation signal+
6	SIN+	AI	Sine signal
7	COS+	AI	Cosine signal
8	GND	-	Chassis, reserved for a twisted pair's shield*
9	COM_B	-	Common
10	EXCITATION-	AO	Excitation signal-
11	GND	-	Chassis, reserved for a twisted pair's shield*
12	COM_B	-	Common
13	COM_B	-	Common
14	GND	-	Chassis, reserved for a twisted pair's shield*
15	GND	-	Chassis, reserved for a twisted pair's shield*
-	Shield	-	Shield

*Optional mounting method for twisted pairs' shields

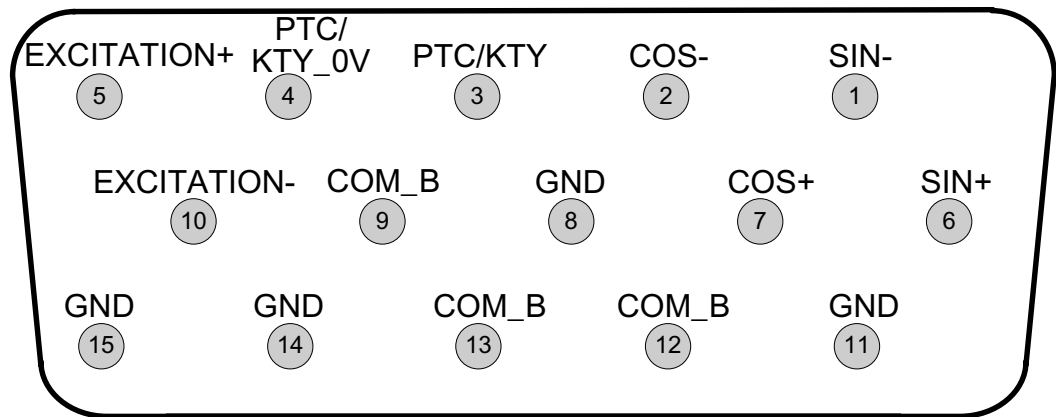

Resolver input (X52) pin order

TTL encoder emulation output (X53)

Pin	Name	Direction	Description
1	A+	DO	Channel A+
2	B+	DO	Channel B+
3	Z+	DO	Channel Z+
4	COM_B	-	Common
5	COM_B	-	Common
6	A-	DO	Channel A-
7	B-	DO	Channel B-
8	Z-	DO	Channel Z-
9	COM_B	-	Common
-	Shield	-	Shield

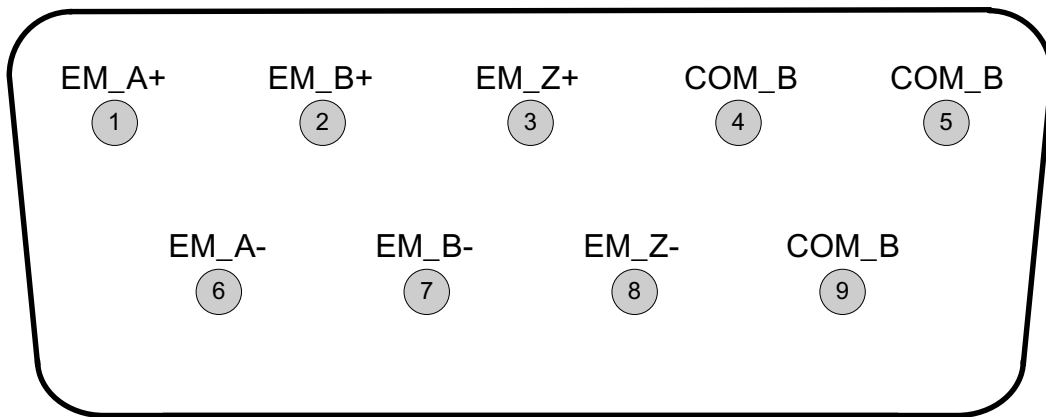

TTL encoder output (X53) pin order

Digital inputs for position latching (X54)

Pin	Name	Direction	Description
1	+24V_C	PO	Supply voltage
2	COM_C	-	Common
3	DI_1+	DI	Latch signal 1
4	DI_1-	-	Latch signal 1 return
5	DI_2+	DI	Latch signal 2
6	DI_2-	-	Latch signal 2 return

Encoder wiring

The resolver and encoder should be connected to the FEN-21 with a shielded instrumentation cable, preferably with twisted pairs. See also the encoder and resolver manual for additional requirements. To prevent the inputs from being disturbed, the cable shield must be connected to the chassis. The connection is made automatically through the metal hood of the plug, if the cables are connected through the cable clamp of the plug.

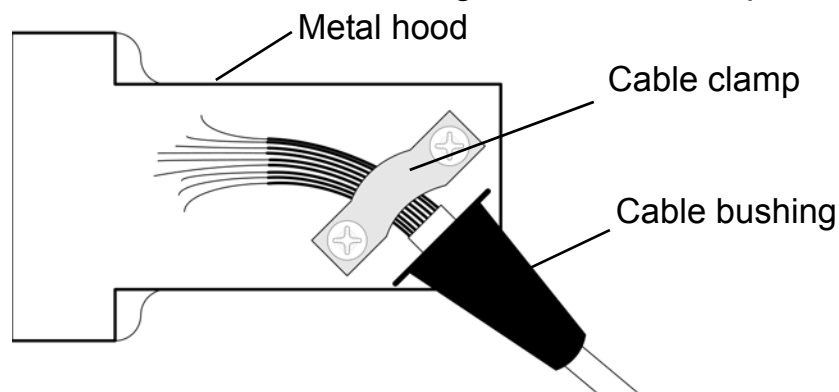

Cable shield connected to the cable clamp

Note: Do not route the encoder cables parallel to power (e.g. motor) cables.

Tightening torque is 0.3 Nm (2.7 lbf·in.) for the plugs.

The allocation of twisted pairs is described for each connector in the following tables.

TTL Encoder input (X51)

The cable should have minimum 4 cable pairs. A fifth cable pair shared between Vcc an 0V pins allows for a longer cable.

Cable pair number	Signals name	X51 connecting plug pin number (9-pins)	Notes
1	A+	1	
	A-	6	
2	B+	2	
	B-	7	
3	Z+	3	
	Z-	8	
4	VCC_ENC_1	5	
	COM_C	9	
5	VCC_ENC_1*	5*	OPTIONAL
	COM_C	4	OPTIONAL

* Two wires soldered to the same pin.

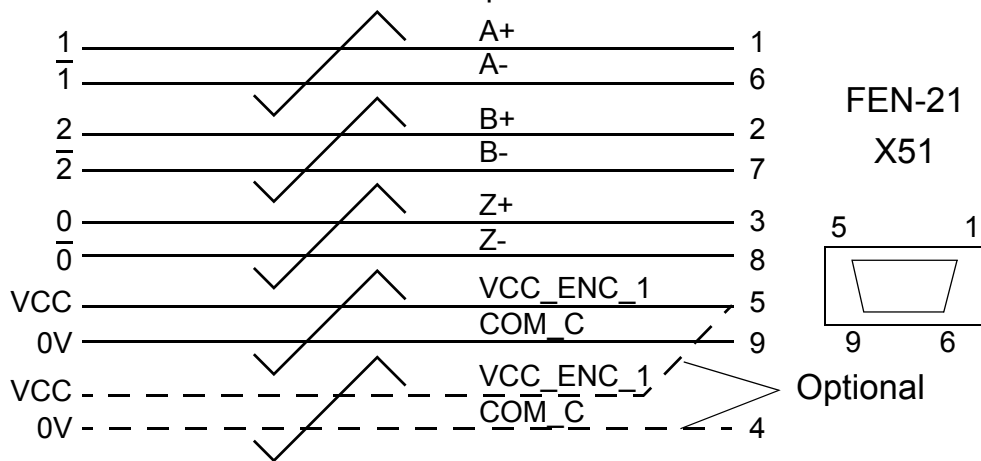

TTL Encoder input (X51)

Resolver input (X52)

The cable should have 4 twisted pairs. Additional 0V and GND pins are reserved for connecting cable shields. The shields should be connected either to 0V or to GND (chassis). Connection of the shields to GND (chassis) can also be made through the D-connector hood cable clamping.

Cable pair number	Signals name	X52 connecting plug pin number (9-pins)	Notes
1	SIN+	6	
	SIN-	1	
2	COS+	7	
	COS-	2	
3	EXCITATION+	5	
	EXCITATION-	10	
4	PTC/KTY-84	3	Temperature sensor
	PTC/KTY_0V	4	Temperature sensor, return
Twisted pair shields connected to 0V	COM_B	9	Shield / optional
	COM_B	12	Shield / optional
	COM_B	13	Shield / optional
Twisted pair shields connected to GND (chassis)	GND	8	Shield / optional
	GND	11	Shield / optional
	GND	14	Shield / optional
	GND	15	Shield / optional

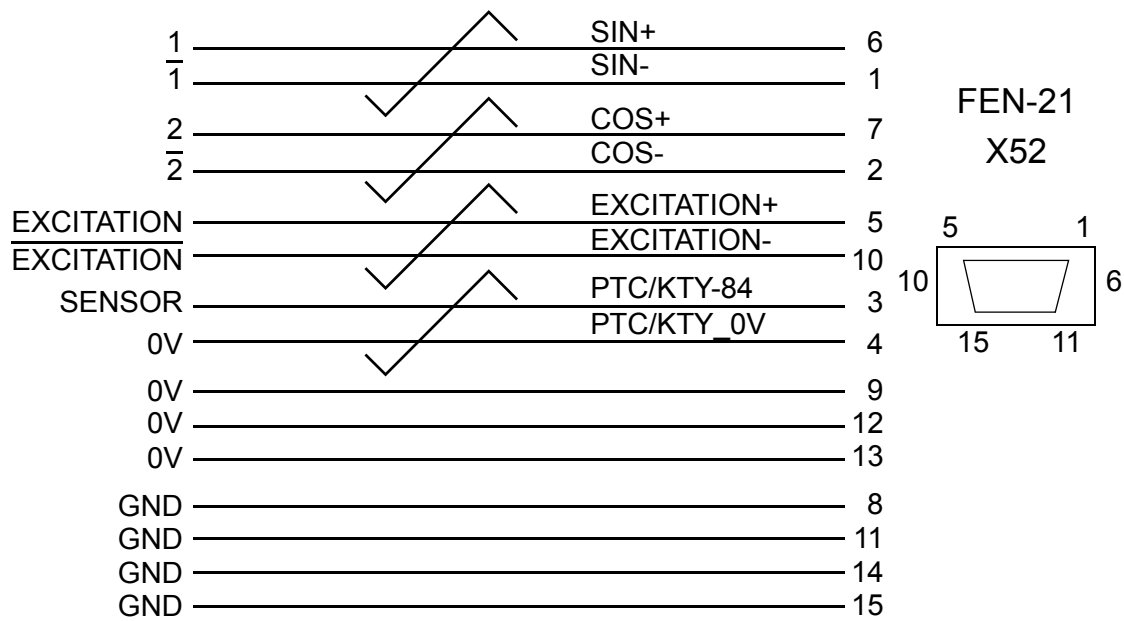

Resolver input (X52)

TTL Encoder emulation output (X53)

The cable should have 4 cable pairs. An extra pair for 0V pins can also be connected.

Cable pair number	Signals name	X53 connecting plug pin number (9-pins)	Notes
1	EM_A+	1	
	EM_A-	6	
2	EM_B+	2	
	EM_B-	7	
3	EM_Z+	3	
	EM_Z-	8	
4	COM_B	4	
	COM_B	9	
5	COM_B	5	OPTIONAL
	COM_B*	9*	OPTIONAL

*Two wires soldered to the same pin.

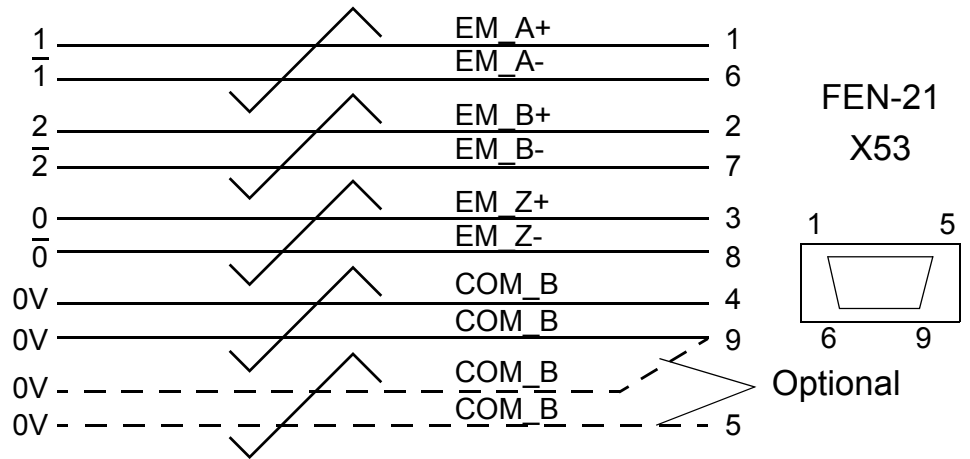

TTL encoder emulation output (X53)

Digital inputs for position latching (X54)

Cable pair number	Signals name	X54 connecting header pin number (6-pins)	Notes
1	+24V_C	1	
	COM_C	2	
2	DI_1+	3	
	DI_1-	4	
3	DI_2+	5	
	DI_2-	6	

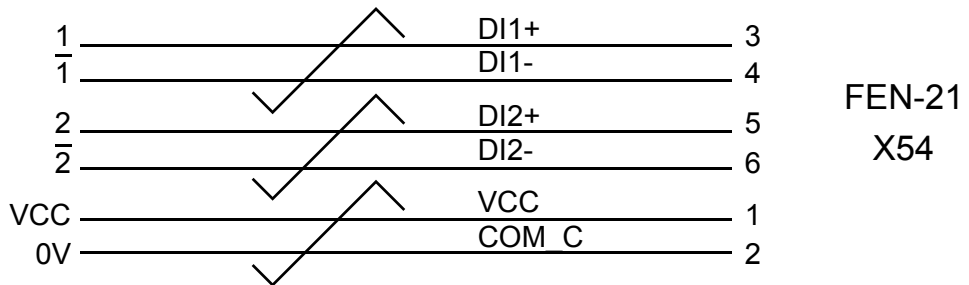

Digital inputs for position latching (X54)

Phasing

When the encoder is connected correctly, running the drive in the *Forward* (positive speed reference) direction should produce a positive encoder speed feedback.

On incremental encoders, the two output channels, usually marked 1 and 2 or A and B, are 90° (electrical) apart from each other. When rotated clockwise, most encoders – but not all – have channel 1 leading channel 2 as illustrated below. Determine the leading channel by referring to the encoder documentation or by measuring with an oscilloscope.

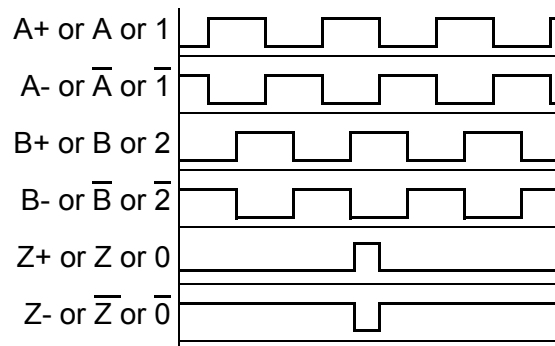

The encoder output channel that leads when the drive runs *Forward* should be connected to FEN-21 input A, the output channel that trails to FEN-21 input B.

The zero reference output channel (usually marked 0, N or Z) needs to be connected in positioning applications only.

Excitation signal

The FEN-21 feeds the resolver differentially with an excitation signal. The amplitude and the frequency are adjustable by software in the following boundaries

Excitation Signal	Amplitude	Frequency	Current, max.
	4...12 V _{rms}	1...20 kHz	100 mA _{rms}

The following figure shows the SIN and COS outputs and the excitation signal.

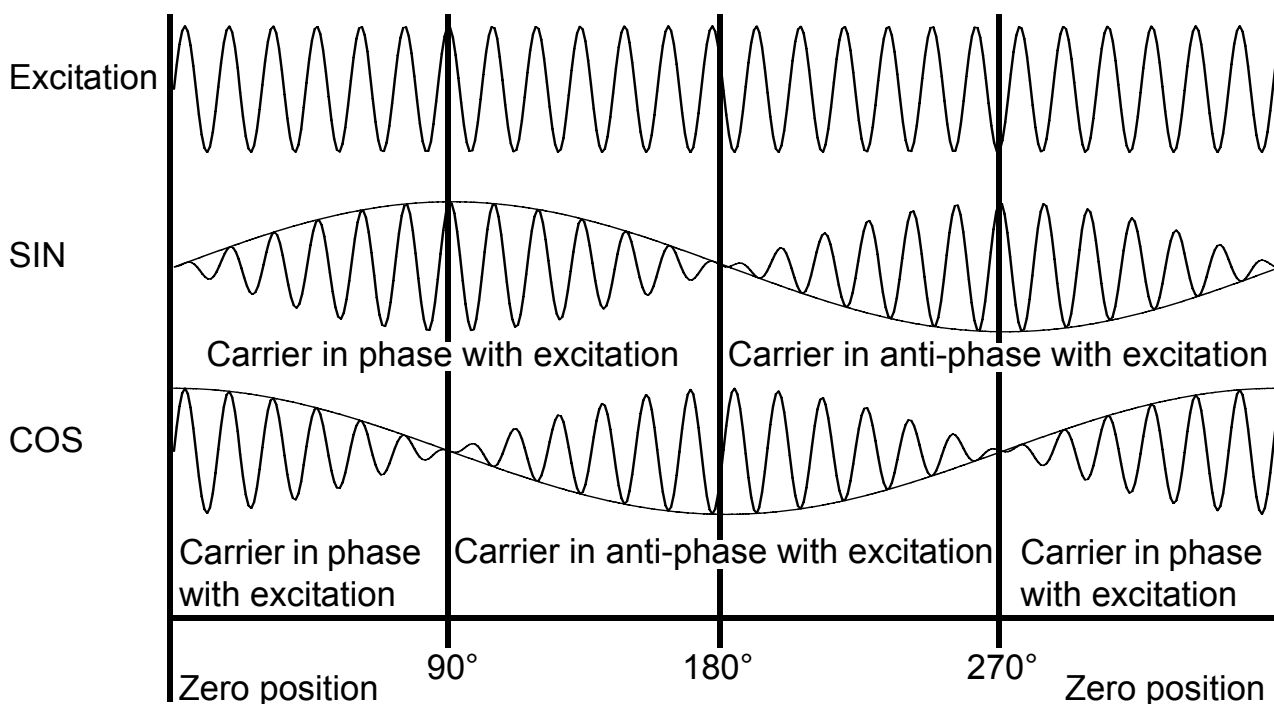

Programming

The FEN-21 is programmed through drive parameters. These parameters must be checked and adjusted according to the encoder and resolver data sheet. For further information, see the drive *Firmware Manual*.

Fault tracing

Diagnostic LEDs

The FEN-21 is equipped with two diagnostic LEDs. The STATUS LED describes the status of the FEN-21 and the ENC ST LED the status of the encoders. Description of the LED signals is presented below.

	Colour	Description
STATUS LED	Green	OK
	Orange	Not initialized or communication fault to control unit
	Red	Not in use
ENC ST LED	Green	Encoder(s) OK
	Red	ENC1 (TTL encoder, X51) fault
	Orange	ENC2 (resolver, X52) fault
	Red / orange swapping	ENC1 fault & ENC 2 fault
	Red flashing	ENC1 warning
	Orange flashing	ENC2 warning

Technical data

Dimensions:

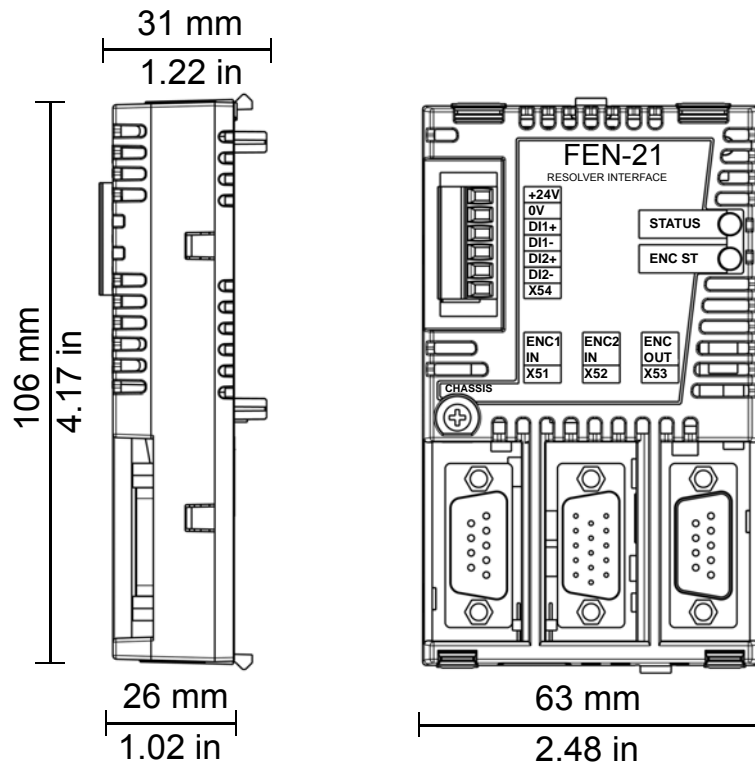

General

- Max. power consumption: 350 mA at 24 V
- Degree of protection: IP20
- Ambient conditions: The applicable ambient conditions specified for the drive in its *Hardware Manual* are in effect.

Connectors

- 20-pin socket
- 9-pin D-sub plug
- 15-pin D-sub plug
- 9-pin D-sub socket
- 6-pin header

TTL encoder input (X51)

- Output voltages:
 - +5.5 V DC +15%, -5%, 180 mA
 - +24 V DC $\pm 15\%$, 150 mA together with digital inputs
 - +5.5 V and +24 V combined maximum power is 3.6 W
- CH A, CH B, CH Z: RS-422/485, differential, 500 kHz (max)
- Maximum cable length:
 - 30 m with a 5 V encoder (0.5 mm² cable)
 - 60 m with a 5 V encoder (two parallel 0.5 mm² cables for power supply)
 - 100 m with a 10...30 V TTL incremental encoder
- Performance:
 - Speed range: -32768...32767 rpm
 - Speed resolution: 0.04 RPM (24 bits)
 - Position resolution: 16 M / rev (24 bits)
 - Position accuracy: 4x pulse count / rev
- Isolated together with digital inputs

Resolver interface

- Output voltage: (AC) 4...12 V_{rms}, 100 mA max.
- Sine & cosine differential inputs 2...7 V_{rms}
- KTY84 or PTC thermistor input
- Performance:
 - Position resolution: 24 bit
 - Speed resolution: 24 bit
- Maximum cable length: 100 m
- Isolated together with TTL encoder emulation output

TTL encoder emulation output (X53)

- Supports emulation of TTL incremental encoder, 1...65535 pulses / rev, zero pulse
- CH A, CH B, CH Z: RS-422/485, 500 kHz (max)
- Maximum cable length: 100 m
- Performance
 - Speed range: -32768...32767 rpm
 - Position resolution: 4x pulse count / rev
- Isolated together with absolute encoder input

Digital inputs for position latch (X54)

- Output voltage: +24 V DC $\pm 15\%$, short-circuit proof
- Signal levels: $< 5\text{ V} = 0$, $> 15\text{ V} = 1$
- Isolated together with TTL encoder input



3AFE68784859 Rev B EN
EFFECTIVE: 16.11.2006

ABB Oy

AC Drives
P.O. Box 184
FIN-00381 HELSINKI
FINLAND

Telephone +358 10 22 11
Telefax +358 10 22 22681
Internet <http://www.abb.com>

ABB Inc.

Automation Technologies
Drives & Motors
16250 West Glendale Drive
New Berlin, WI 53151
USA

Telephone 262 785-3200
800-HELP-365
Telefax 262 780-5135

**ABB Beijing Drive Systems
Co. Ltd.**

No. 1, Block D,
A-10 Jiuxianqiao Beilu
Chaoyang District
Beijing, P.R. China, 100015

Telephone +86 10 5821 7788
Fax +86 10 5821 7618