

ABB Drives

User's Manual Analog I/O Extension FIO-11

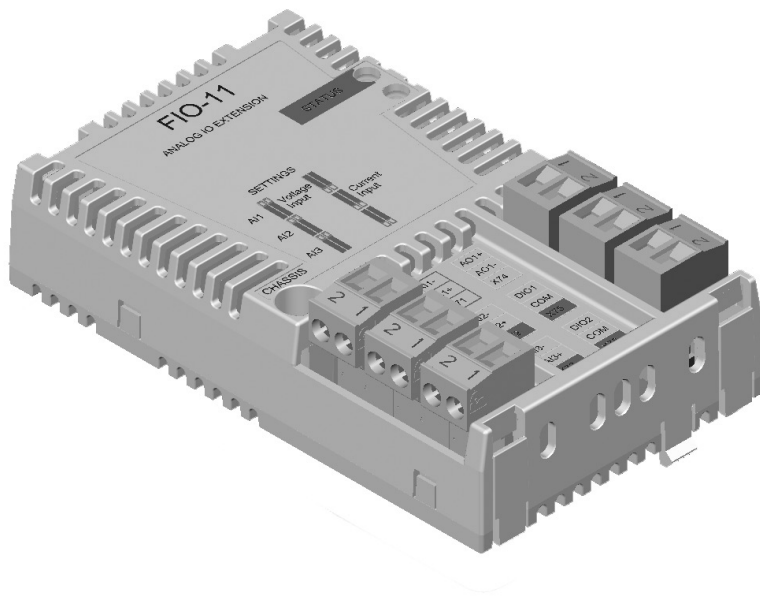

Analog I/O Extension
FIO-11

User's Manual

3AFE68784930 Rev B EN

EFFECTIVE: 15.12.2006

Safety instructions

Overview

This chapter states the general safety instructions that must be followed when installing and operating the FIO-11 Analog I/O Extension.

In addition to the safety instructions given below, read the complete safety instructions of the specific drive you are working on.

These warnings are intended for all who work on the drive. Ignoring the instructions can cause physical injury or death, or damage the equipment.

General safety instructions



Warning! All electrical installation and maintenance work on the drive should be carried out by qualified electricians only.

The drive and adjoining equipment must be properly earthed.

Do not attempt any work on a powered drive. After switching off the mains, always allow the intermediate circuit capacitors 5 minutes to discharge before working on the frequency converter, the motor or the motor cable. It is good practice to check (with a voltage indicating instrument) that the drive is in fact discharged before beginning work.

The motor cable terminals of the drive are at a dangerously high voltage when mains power is applied, regardless of motor operation.

There can be dangerous voltages inside the drive from external control circuits even when the drive mains power is shut off. Exercise appropriate care when working on the unit.

Table of contents

Safety instructions	5
Overview	5
General safety instructions	5
 Table of contents	 7
 Introduction	 9
Intended audience	9
Before you start	9
What this manual contains	9
 Overview	 11
Overview	11
The FIO-11 Analog I/O Extension	11
 Installation	 13
Mounting	13
Input signal type selection	14
Terminal designations	14
Wiring	15
Programming	16
 Fault tracing	 17
Diagnostic LEDs	17
 Technical data	 19

Introduction

Intended audience

The manual is intended for the people who are responsible for commissioning and using the FIO-11 Analog I/O Extension. The reader is expected to have a basic knowledge of electrical fundamentals, electrical wiring practices and how to operate the drive.

Before you start

It is assumed that the drive is installed and the drive power supply is switched off before starting the installation of the extension module. Ensure that all dangerous voltages connected from external control circuits to the inputs and outputs of the drive are switched off.

In addition to conventional installation tools, have the drive manuals available during the installation as they contain important information not included in this manual. The drive manuals are referred to at various points of this document.

What this manual contains

This manual contains information on the wiring, configuration and use of the FIO-11 Analog I/O Extension.

Safety instructions are featured in the first few pages of this manual.

Overview contains a short description of the FIO-11.

Installation contains instructions for hardware settings, mounting and cabling.

Fault tracing explains LED indications.

Technical Data contains detailed technical information.

Overview

Overview

This chapter contains a short description of the FIO-11 Analog I/O Extension.

The FIO-11 Analog I/O Extension

The FIO-11 is a general purpose analog and digital input/output extension. It offers three analog inputs, one analog output and two digital inputs or outputs. All inputs and outputs are in the same potential and have a common isolation to control electronics.

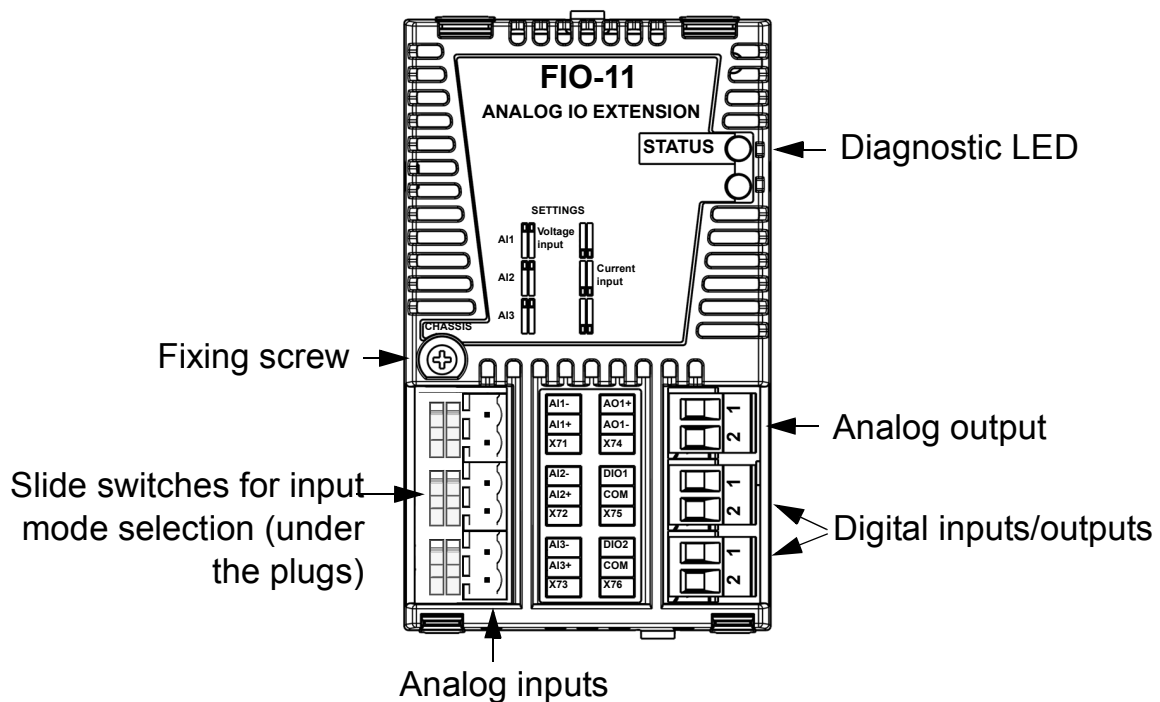

FIO-11 layout

Isolation areas

The following figure describes the different isolation areas of the module.

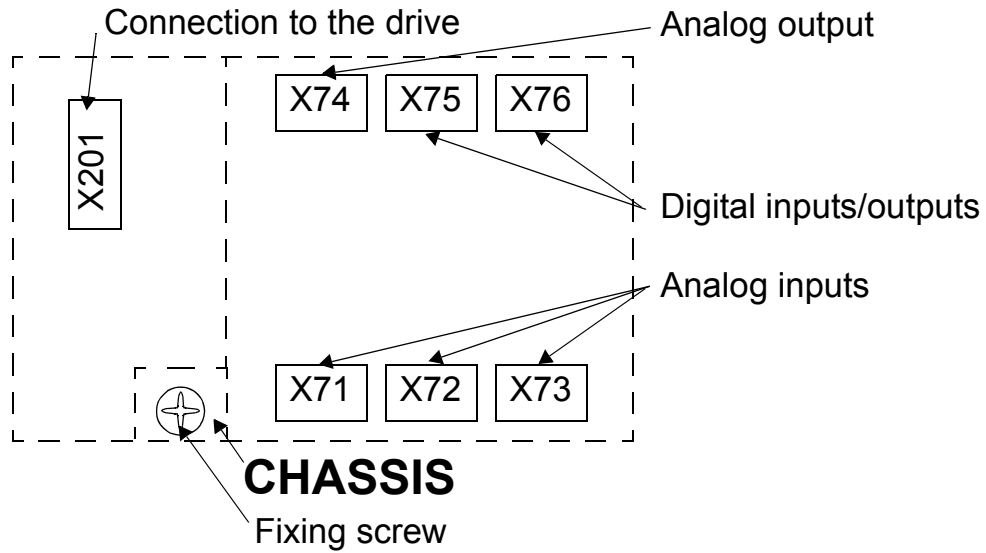

The fixing screw connects the chassis to ground.

Installation



Warning! Follow the safety instructions given in this guide and in the drive's hardware manual.

Mounting



Warning! Before installation, switch off the drive power supply. Wait for five minutes to ensure that the capacitor bank of the drive is discharged. Switch off all dangerous voltages connected from external control circuits to the inputs and outputs of the drive.

The FIO-11 is to be inserted into the option slot of the drive. The module is held in place with plastic retaining clips and one screw. On installation of the module, the signal and power connection to the drive is automatically made through a 20-pin connector.

Mounting procedure:

- Insert the module carefully into the option slot until the retaining clips lock the module into position.
 - Fasten the screw (included) to the stand-off.
-

Note: Correct installation of the screw is essential for fulfilling the EMC requirements and for proper operation of the module.

Input signal type selection

The three analog inputs can be used with a current or voltage signal. The selection is made by sliding the both slide switches next to the input either up (current signal) or down (voltage signal).

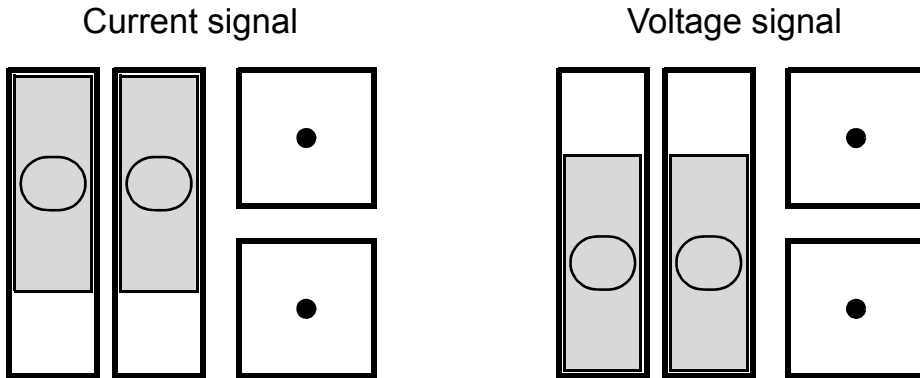

Terminal designations

Marking		Description
X71		Analog input • Current input -20...20 mA • Voltage input -10...10 V
1	AI1+	
2	AI1-	
X72		
1	AI2+	
2	AI2-	
X73		
1	AI3+	
2	AI3-	
X74		Analog output • Current output: 0...20 mA
1	AO1+	
2	AO1-	
X75		Digital input/output • 24 V logic levels for input: "0" < 5 V, "1" > 15 V • Output current 50 mA source, 50 mA sink
1	DIO1	
2	COM	
X76		
1	DIO2	
2	COM	

Wiring

The diagram presents some typical output types.

Push-pull	Open collector (Sinking)	Open emitter (Sourcing)
<p>V_{CC} = Digital I/O power supply voltage R_L = Load at output channel</p>		

Maximum 2.5 mm² cable should be used for the signals. The cable shields should be connected to the JCU-01 Control Unit. See the drive *Hardware Manual* for more information.

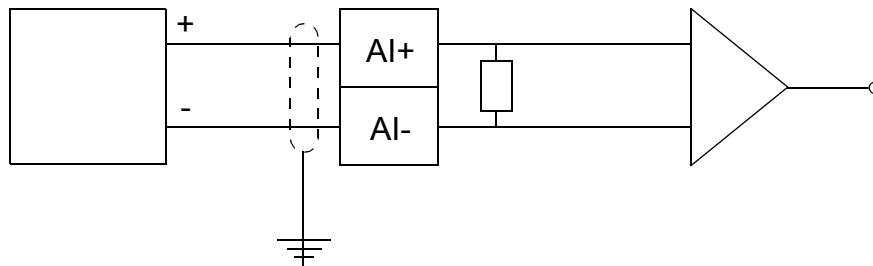

Analog input description

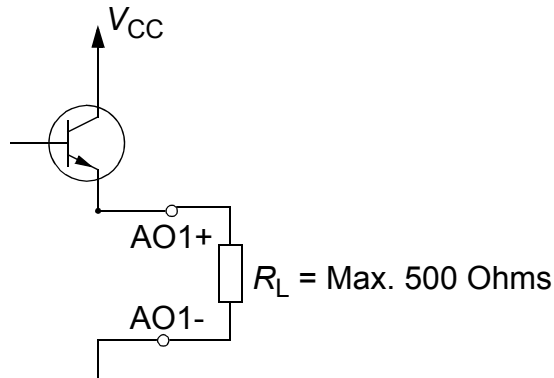

Analog output description

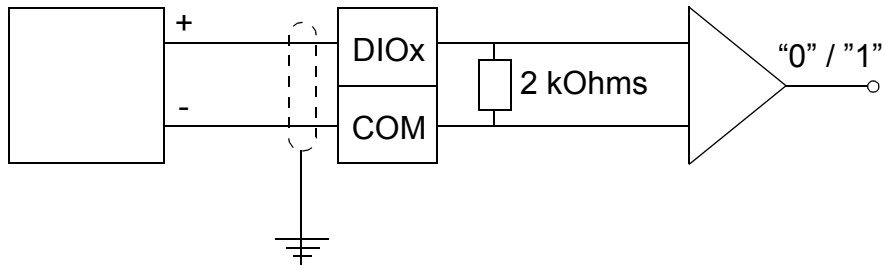

Digital I/O description

Note: Do not route signal cables parallel to power cables.

Tightening torque is 0.5 Nm (4.4 lbf·in.) for the plugs.

Programming

The communication between the module and the drive is activated by a drive parameter. See the drive *Firmware Manual*.

Fault tracing

Diagnostic LEDs

	Colour	Description
STATUS LED	Green	OK
	Orange	Not initialized or communication fault to control unit
	Red	Power fault & not initialized or communication fault to control unit

Technical data

Dimensions

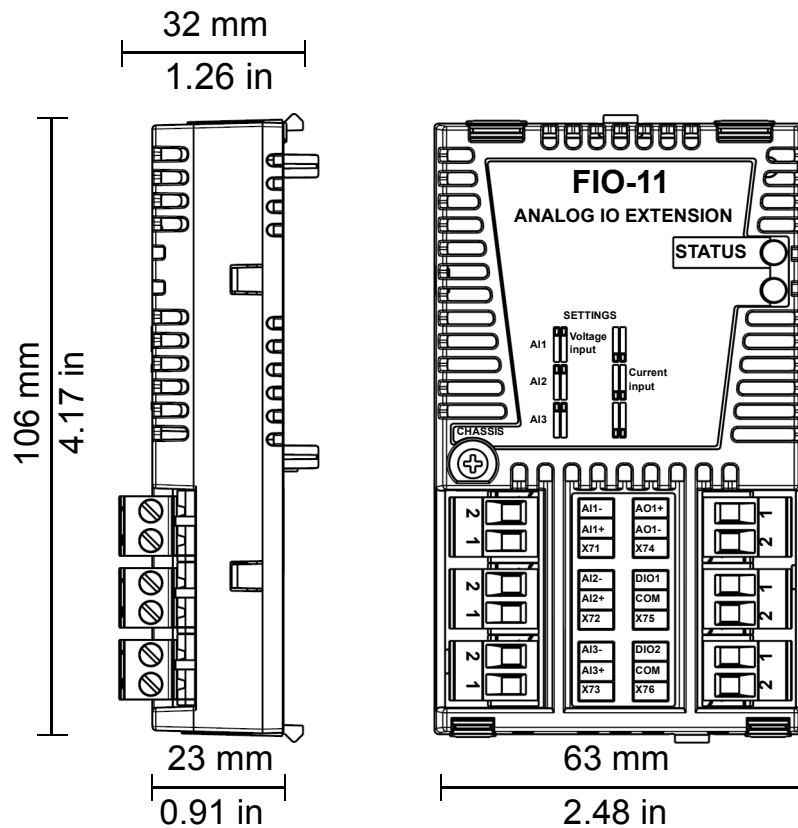

General

- Max. power consumption: 300 mA at 24 V
- Degree of protection: IP20
- Ambient conditions: The applicable ambient conditions specified for the drive in its *Hardware Manual* are in effect

Connectors

- 20 pin socket
- 6 pcs. 2-pole detachable terminal plugs.

Analog input

- Input voltages: -10...10 V
- Input currents: -20...20 mA
- Differential inputs, common-mode voltage ± 20 V
- Analog to digital conversion resolution 16 bit
- Inaccuracy: 0.1% of FSR
- Input signal bandwidth DC to 4 kHz (-3 dB)
- Isolated from power supply.

Analog output

- Output current: 0...20 mA, $R_{load} < 500$ ohms
- Resolution 16 bit
- Inaccuracy 2% FSR
- Output signal bandwidth DC to 4 kHz (-3 dB).

Digital I/O

- All DIOs programmable as
 - Input (default)
 - Push-pull output
 - Open collector output
- Input voltages max 30 V, reverse polarity protection
- 24 V logic levels for input: "0" < 5 V, "1" > 15 V (according to standard IEC 61131-2)
- Input impedance 2 kOhms
- Output current 50 mA source, 50 mA sink
- Outputs are short-circuit proof
- Galvanic isolation as one group



ABB Oy

AC Drives

P.O. Box 184

FIN-00381 HELSINKI

FINLAND

Telephone +358 10 22 11

Telefax +358 10 22 22681

Internet <http://www.abb.com>**ABB Inc.**

Automation Technologies

Drives & Motors

16250 West Glendale Drive

New Berlin, WI 53151

USA

Telephone 262 785-3200

800-HELP-365

Telefax 262 780-5135

**ABB Beijing Drive Systems
Co. Ltd.**

No. 1, Block D,

A-10 Jiuxianqiao Beilu

Chaoyang District

Beijing, P.R. China, 100015

Telephone +86 10 5821 7788

Fax +86 10 5821 7618

3AFE68784930 Rev B EN
EFFECTIVE: 15.12.2006