

User Manual

EM882S

Digital Microstepping Drive



Revision 1.0

©2017 Leadshine Technology Co., Ltd.

UK Official Distributor Address:

Motion Control Products Ltd, 11-15 Francis Avenue, Bournemouth, Dorset, BH11 8NX, United Kingdom

Tel: +44(0)1202 599922

Fax: +44 (0)1202 599955

Web: www.motioncontrolproducts.com

Sales: enquiries@motioncontrolproducts.com

Important Notice

Read this manual carefully before any assembling and using. Incorrect handling of products in this manual can result in injury and damage to persons and machinery. Strictly adhere to the technical information regarding installation requirements.

This manual is not for use or disclosure outside of Leadshine except under permission. All rights are reserved. No part of this manual shall be reproduced, stored in retrieval form, or transmitted by any means, electronic, mechanical, photocopying, recording, or otherwise without approval from Leadshine. While every precaution has been taken in the preparation of the book, Leadshine assumes no responsibility for errors or omissions. Neither is any liability assumed for damages resulting from the use of the information contained herein.

This document is proprietary information of Leadshine that is furnished for customer use ONLY. Information in this document is subject to change without notice and does not represent a commitment on the part of Leadshine. Therefore, information contained in this manual may be updated from time-to-time due to product improvements, etc., and may not conform in every respect to former issues.

Record of Revisions

Revision	Date	Description of Release
<i>1.0</i>	<i>Oct, 2017</i>	<i>Initial Release</i>

Table of Contents

1. Introduction	1
1.1 Features	1
1.2 Applications	1
2. Specifications	2
2.1 Electrical Specifications.....	2
2.2 Environment	2
2.3 Mechanical Specifications.....	2
2.4 Elimination of Heat	3
3. Connection Pin Assignments and LED Indication	3
3.1 P1 - Control Connector Configurations.....	3
3.2 P2 - Fault Output Connector.....	4
3.3 P3 - Motor and Power Connector.....	4
3.4 P4 - Tuning Port.....	4
3.5 Status LED Lights	4
4. Control Signal and Fault Output	4
4.1 Control Signal Connection	4
4.2 Fault Output Connection	5
5. Stepper Motor Connections	5
5.1 4-lead Motor Connection (recommended).....	5
5.2 6-lead Motor Connection	6
5.3 8-lead Motor Connection	6
6. Power Supply Selection	6
6.1 Regulated or Unregulated Power Supply.....	7
6.2 Power Supply Sharing	7
6.3 Selecting Supply Voltage.....	7
7. DIP Switch Configurations	7
7.1 Output Current Configuration (SW1-3).....	7
7.2 Idle Current Configuration (SW4).....	8
7.3 Micro Step Configuration (SW5-8).....	8
7.4 Auto-tuning and Motor Model Selection (Rotary Switch)	9
7.5 Smoothing Filter Time Configuration (ProTuner).....	9
7.6 Activated Pulse Edge Configuration (ProTuner).....	9
7.7 Control Mode Configuration (ProTuner).....	9
8. Wiring Notes	9
9. Typical Connection	10
10. Sequence Chart of Control Signals	10
11. Protection Functions	11
12. Troubleshooting	12
13. Warranty	13
TWELVE MONTH LIMITED WARRANTY	13
EXCLUSIONS	13
SHIPPING FAILED PRODUCT & OBTAINING WARRANTY SERVICE	13
WARRANTY LIMITATIONS.....	13

1. Introduction

The EM882S is a new digital stepper drive based on Leadshine's widely implemented DM stepper drives (10+ millions of units in field). While retaining features of simple design, easy setup, high precision and reliability, Leadshine has also upgraded it by adopting the latest stepper control technology and added additional advanced features for better torque (10-25%), quicker response time, control command smoothing, motor selector, etc.

The EM882S is able to power 2 phase (1.8°) and 4 phase (0.9°) stepper motors smoothly with very low motor heating & noise. It can take 20-80VDC supply voltage and output 0.5 to 8.2A current. All the micro step, output current configurations and motor model selection can be easily done via built in DIP switches. Therefore, the EM882S is an ideal choice for many applications requiring simple step & direction or CW/CCW control of NEMA 23, 24 and 34 stepper motors.

1.1 Features

- Step & direction (PUL/DIR) or CW/CCW (double pulse) control
- 20-80VDC supply voltage
- 200 KHz max pulse input frequency
- 16 microstep resolutions of 400-51,200 via DIP switches, or 200-51,200 via software (increase by 200)
- 8 output current settings of 2.1-8.2A via DIP Switches, or 0.5-8.2A via software (increase by 0.1)
- Configurable control command smoothing for reducing motor vibration
- Idle current reduction to 50% or 100% selection via SW4
- Sensor-less stall detection
- Auto-tuning and motor model selection to match wide-range stepper motors
- Anti-Resonance for optimal torque, extra smooth motion, low motor heating and noise
- Soft-start with no "jump" when powered on
- Fault output
- Over-voltage, over-current protections
- CE certified and RoHS compliant

1.2 Applications

The EM882S stepper drive is designed to power 2 phase (1.8°) or 4-phase (0.9°) NEMA23, 24 and 34 hybrid stepper motors. It can be adopted in many industries (CNC machinery, electronics, medical, automation, packaging...) for applications such as CNC routers, mills, plasma, laser cutters, factory assembly lines, vending machines, etc. Its excellent performance, simple design, and easy setup features make EM882S ideal for many step & direction control type applications.

2. Specifications

2.1 Electrical Specifications

Parameters	Min	Typical	Max	Unit
Output Current	0.5	-	8.2 (5.9 RMS)	A
Supply Voltage	20	24 - 72	80	VDC
Logic signal current	7	10	16	mA
Pulse input frequency	0	-	200	kHz
Minimal pulse width	2.5	-	-	μs
Minimal direction setup	5.0	-	-	μs
Isolation resistance	500	-	-	MΩ

2.2 Environment

Cooling	Natural Cooling or Forced cooling	
Operating Environment	Environment	Avoid dust, oil fog and corrosive gases
	Ambient Temperature	0 — 65°C (32 - 149°F)
	Humidity	40 — 90%RH
	Operating Temperature	0 — 50°C (32 - 122°F)
	Vibration	10-50Hz / 0.15mm
Storage Temperature	-20°C — 65°C (-4°F - 149°F)	
Weight	Approx. 500g (1.1 oz)	

2.3 Mechanical Specifications

(unit: mm [1inch=25.4mm])

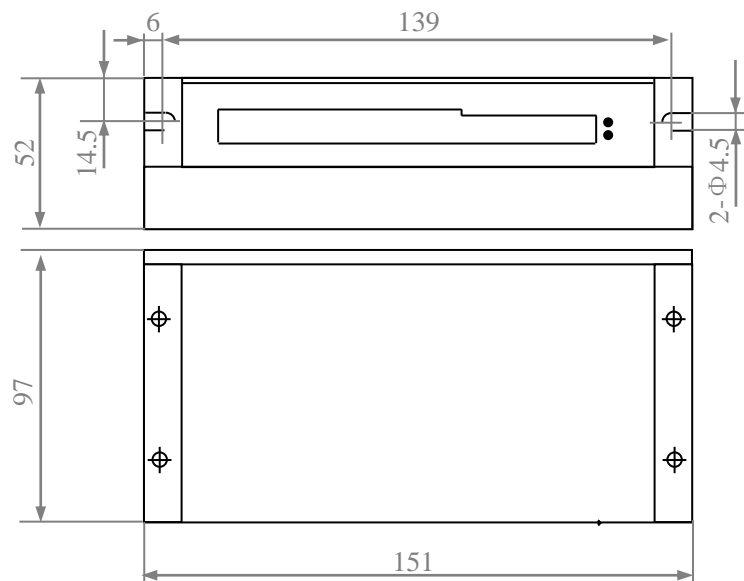

Figure 1: Mechanical specifications

Figure 1 Mechanical specifications

* Side mounting recommended for better heat dissipation

2.4 Elimination of Heat

- EM882S's working temperature is less than 60°C (140°F)
- It is recommended to use automatic idle-current mode to reduce motor heating. That means set the SW4 pin of DIP switch at "OFF" position.
- It is recommended to mount the drive vertically to maximize heat sink area. Use forced cooling method to cool if necessary.

3. Connection Pin Assignments and LED Indication

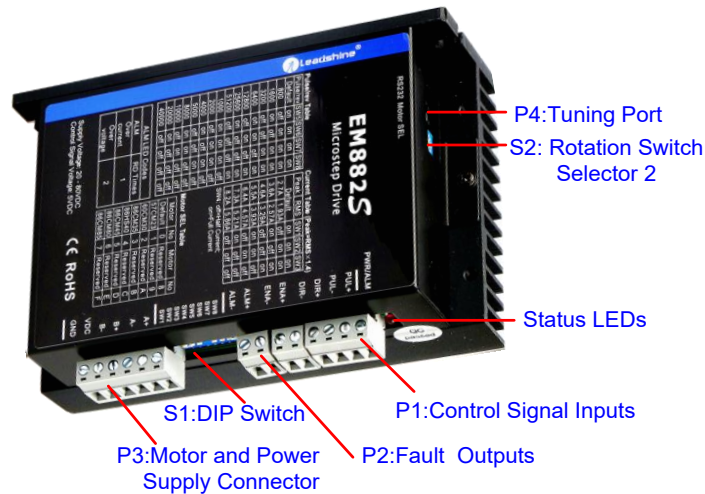

Figure 2 Connectors, DIP switches, and LED locations

The EM882S has 4 connectors P1, P2, P3 and P4, 2 DIP switch S1 and rotation switch S2. P1 is for control signal connections, P2 is for fault output, P3 is for motor and power connection, P4 is for fine tuning.

3.1 P1 - Control Connector Configurations

PIN	Details	
PUL+ (CW+)	<u>Pulse and Direction Connection:</u> (1) Optically isolated, high level 4.5-5V, low voltage 0-0.5V (2) Maximum 200 KHz input frequency (3) The width of PUL signal is at least 2.5μs, duty cycle is recommended 50% (4) Single pulse (step & direction) or double pulse (CW/CCW) is set by Leadshine ProTuner (5) DIR signal requires advance PUL signal minimum 5 μs in single pulse mode (6) The voltage of control signal is 5V, need to connect a 2K resistance when it is 24V	
PUL- (CW-)		
DIR+ (CCW+)		
DIR- (CCW-)		
ENA+		<u>Enable Connection:</u> Optional. (1) Optically isolated, differential. (2) Disable the drive by 4.5-5.0V input connection; enable the drive by 0-0.5V connection (default no connection)
ENA-		(3) ENA signal requires advance DIR signal minimum 5μs in single pulse mode (4) Enable time to be at least 200ms



Notes: (1) shield cables are required for P1; (2) don't tie P1/P2 cables and P3/P4 cables together.

3.2 P2 - Fault Output Connector

Pin	Details
ALM+	<u>Fault Output Connection:</u> Optional. (1) Maximum 24V/80mA output when over-voltage and over-current error protections activated. (2) Sinking or sourcing. (3) The resistance between ALM+ and ALM- is low impedance as default, and will change to high when the drive goes into error protection.
ALM-	

3.3 P3 - Motor and Power Connector

PIN	Details
A+	Connect to motor A+ wire
A-	Connect to motor A- wire
B+	Connect to motor B+ wire
B-	Connect to motor B- wire
+VDC	Connect to power supply positive connection. Suggest 24-72VDC power supply voltage
GND	Connect to power supply ground connection.



Warning: Don't plug/unplug P3 connector to avoid drive damage or injury while powered on.

3.4 P4 - Tuning Port

EM882S has a tuning port with RS232 to modify the drive parameters, it's only for tuning, not for equipment control because neither precision nor stability is sufficient. If you need a field bus drive, contact Motion Control Products Ltd. For their range of fieldbus servo drives and stepper drives, ideal for performance network control.

www.motioncontrolproducts.com

The interface definition is as follows:

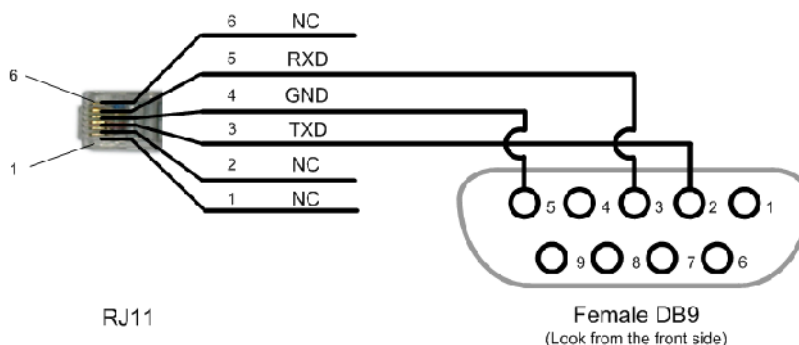

3.5 Status LED Lights

There are two LED lights for EM882S. The GREEN one is the power indicator which should be always on in normal circumstance. The RED one is a drive status indication light, which will be OFF while working normally but ON and flash 1 or 2 times in a 3-second period in the case of enabled over-current or over-voltage protection.

4. Control Signal and Fault Output

4.1 Control Signal Connection

The EM882S can accept differential or single-ended control signals (pulse, direction, and enable) in open-collector or

PNP connection through the P1 connector (figure 2). It is recommend to add an EMI line filter between the power supply and the drive to increase noise immunity for the drive in interference environments.

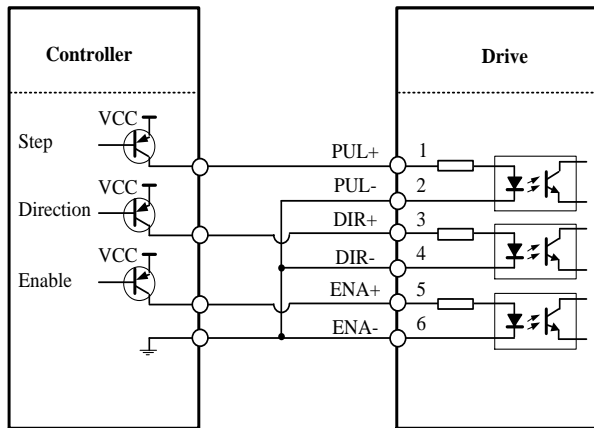

Figure 3 Connections to open-collector signals (Common-anode)

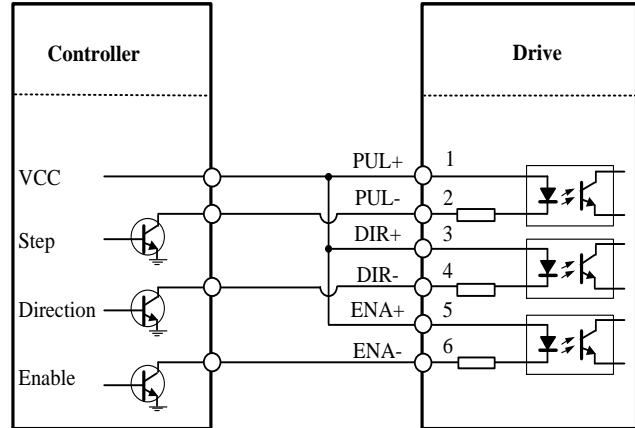

Figure 4 Connections to PNP signals (Common-cathode)

4.2 Fault Output Connection

When over voltage or over current protection happens, EM882S red status LED light will blink and the impedance state between ALM+ and ALM- will change (from low to high or high to low depending on configuration) and can thus be detected. Fault output connection is optional, and it can be connected either in sinking or sourcing.

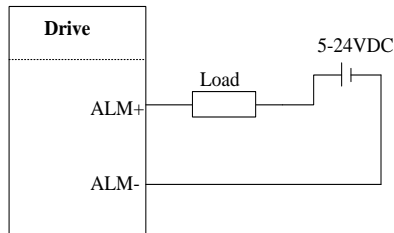

Figure 5 Sinking output

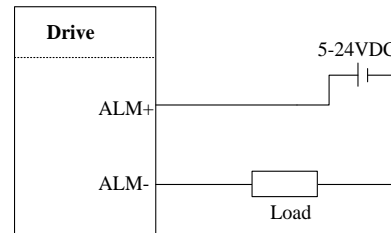

Figure 6 Sourcing output

5. Stepper Motor Connections

EM882S can drive 2-phase and 4-phase bipolar hybrid stepper motors with 4, 6, or 8 leads, Motion Control Products also offers easy-to-use and good-performance motors with 4-leads, ideal for running with the EM882S:

<https://www.motioncontrolproducts.com/electric-motors/stepper-motors/hybrid-stepper-motors/>

5.1 4-lead Motor Connection (recommended)

4-lead motor is easy to use with excellent performance. Refer to figure 8 for how to connect a 4-lead stepper motor.

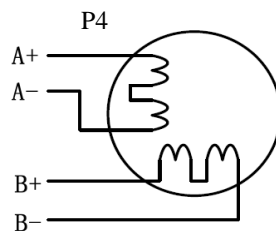

Figure 7 4-lead Motor Connection

5.2 6-lead Motor Connection

EM882S can power 6-lead stepper motors through half coil connection (half chopper) or full coil (full copper) connection. The half coil connection only uses one half of the motor's winding and is usually selected in applications requiring high speed but lower torque. The full coil connection uses the full coil winding and is usually selected in high-torque required applications. Refer to figure 8 and 9 for those two connections.

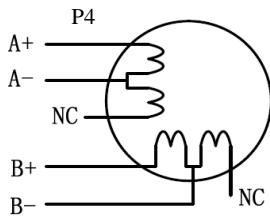

Figure 8 6-lead motor half coil connection

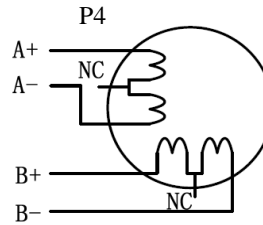

Figure 9 6-lead motor full coil connection

5.3 8-lead Motor Connection

EM882S can power 8-lead in series or parallel connection in series or parallel.

Series connected 8-lead stepper motors are typically implemented in applications which higher torque at lower speed movement is required. Because a stepper motors under series connection has the most inductance, the performance will start to degrade when the motor runs at higher speed. For this connection, it is suggested to set an EM882S's output RMS current to no more than 70% of the stepper motor's phase current to prevent overheating. See the figure 10 for how to connect an 8-lead stepper motor for series connection.

Parallel connected 8-lead stepper motors are typically implemented in applications which higher torque at high speed movement is required. Compared with series connection, a parallel connected stepper motor has lower inductance and therefore have better torque performance at higher speed movement. Although setting the drive output current to 1.4 times of driven motor phase current will get the most torque, it is suggested to set an EM882S's output current (peak of sinusoidal) to no more than 1.2 times the stepper motor's phase current to prevent overheating. Refer to the figure 11 for how to connect an 8-lead stepper motor for parallel connection.

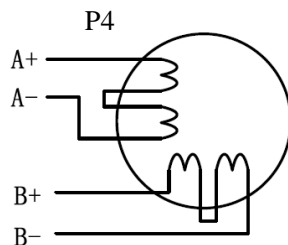

Figure 10 8-lead motor series connection

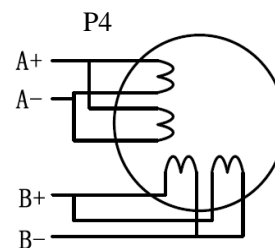

Figure 11 8-lead motor parallel connection

6. Power Supply Selection

EM882S is designed to power stepper motors (frame sizes NEMA 23 to 34) made by Leadshine or other motor manufacturers. To get optimal performances, it is important to select proper power supply type, voltage, and supply output current. In general power supply voltage determines the high speed performance of a stepper motor, while drive output current determines the driven motor torque output. Higher supply voltage can increase motor speed torque performance, but at the same time result in more noise and motor heating. For low motor speed applications,

it is suggested to use lower supply voltage power supplies.

6.1 Regulated or Unregulated Power Supply

Both regulated and unregulated power supplies can be used to power an EM882S. Theoretically unregulated power supplies are preferred due to their ability to withstand back EMF current surge and faster response for current change. If you prefer to use a regulated power supply instead, it is suggested to choose one specially designed for stepper or servo controls. In the case when only general purpose switching power supplies are available, choose one with "OVERSIZED" current output rating (for example, using a 4A power supply for 3A stepper motor) to avoid current clamp. On the other hand, if unregulated supply is used, one may use a power supply of lower current rating than that of motor (typically 50% - 70% of motor phase current). The reason is that the drive only draws current from an unregulated power supply during the ON duration of the PWM cycle, but not during the OFF duration.

6.2 Power Supply Sharing

Multiple EM882S drives can share the same power supply, if that power supply has enough capacity. To avoid cross interference, connect each EM882S DIRECTLY to that shared power supply separately instead of connecting those power connectors of drives in daisy-chain connection.

6.3 Selecting Supply Voltage

EM882S's operating voltage is 20-80 VDC. Because of voltage increasing from potential power line voltage fluctuation and back EMF voltage generated during motor deceleration, it is suggested to use a 24-72 VDC power supply.

7. DIP Switch Configurations

The EM882S has one 8-bit DIP switch and one 16-bit rotation switch selector. "Default" means that parameters can be modified by Leadshine ProTuner software.

The DIP switch S1 in Figure 2 and used to configure settings of micro step resolution, output current, and motor standstill current as shown below, the factory setting of SW1-SW8 is **ON, ON, ON, OFF, ON, ON, ON, ON**.

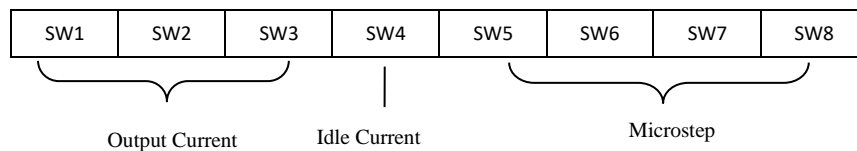

The rotation Switch S2 is located on the top (rotation switch selector 2 in figure 2) for motor selection.

7.1 Output Current Configuration (SW1-3)

The EM882S has 8 output current settings which can be configured through DIP switch SW1, SW2 and SW3.

For a given stepper motor, as normal setting the output current to 1.4 times of motor phase current, will make it output larger torque, but at the same time cause more heating for both the motor and drive. Therefore, it is suggested to set a output current (peak of sinusoidal) to no more than 1.2 times the stepper motor's (for 4-lead motor) phase current to prevent overheating .

The SW1, SW2 and SW3 are used to set the dynamic current. Select a setting closest to your motor's required current. When they are set to **ON, ON, ON**, the output current can be set by Leadshine ProTuner.

Peak Current	RMS Current	SW1	SW2	SW3
2.1A	1.48A (default)	ON	ON	ON
2.7A	1.93A	OFF	ON	ON
3.6A	2.57A	ON	OFF	ON
4.6A	3.29A	OFF	OFF	ON
5.5A	3.93A	ON	ON	OFF
6.4A	4.57A	OFF	ON	OFF
7.3A	5.21A	ON	OFF	OFF
8.2A	5.86A	OFF	OFF	OFF

7.2 Idle Current Configuration (SW4)

The SW4 of an EM882S is used to set output current percentage when motor is standstill. Idle current percentage will be set to 50% at OFF position, and 100% at ON position. When the driven stepper motor is idle (no movement) for 0.4 second, the output current of EM882S will be automatically reduced to the configured percentage.

7.3 Micro Step Configuration (SW5-8)

Each EM882S has 8 micro step settings which can be configured through DIP switch SW5, SW6, SW7 and SW8. See the following table for detail. When they are set to **ON, ON, ON,ON**, the microstep can be set via Leadshine ProTuner.

Micro step	Pulses/Rev. (for 1.8°motor)	SW5	SW6	SW7	SW8
2	400 (default)	ON	ON	ON	ON
4	800	OFF	ON	ON	ON
8	1600	ON	OFF	ON	ON
16	3200	OFF	OFF	ON	ON
32	6400	ON	ON	OFF	ON
64	12800	OFF	ON	OFF	ON
128	25600	ON	OFF	OFF	ON
256	51200	OFF	OFF	OFF	ON
5	1000	ON	ON	ON	OFF
10	2000	OFF	ON	ON	OFF
20	4000	ON	OFF	ON	OFF
25	5000	OFF	OFF	ON	OFF
40	8000	ON	ON	OFF	OFF
50	10000	OFF	ON	OFF	OFF
100	20000	ON	OFF	OFF	OFF
200	40000	OFF	OFF	OFF	OFF

7.4 Auto-tuning and Motor Model Selection (Rotary Switch)

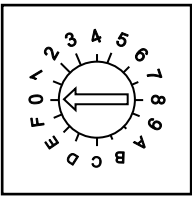
	Motor	Code	Motor	Code
	Default	0	Reserved	8
	57CM23	1	Reserved	9
	60CM30X	2	Reserved	A
	86CM35	3	Reserved	B
	86HS40	4	Reserved	C
	86CM45	5	Reserved	D
	86CM80	6	Reserved	E
	86CM85	7	Reserved	F

Auto-tuning means that the current loop parameters are automatically configured when the EM882S is powered on. When the rotary switch is set to “0”, or “8” - “F”, you can turn off auto-tuning and modify current loop parameters through ProTuner

Motor Model Selection means that the current loop parameters and resonant point damping parameters are automatically configured when EM882S is powered on.

Every time change the rotary switch, you need to restart the power supply to activate the setting.

7.5 Smoothing Filter Time Configuration (ProTuner)

EM882S has an advanced feature called control command smoothing to make the input pulse from pulse generator (controller, PLC, etc.) S-curve acceleration, to improve motion smoothness and high-speed start frequency in many circumstances. The Filter Time value must be set to the same for each EM882S in multi-axis applications

7.6 Activated Pulse Edge Configuration (ProTuner)

The factory setting is activated at voltage rising edge, make sure this setting will match the pulse generator (controller, PLC, etc.). When the stepper motors loss step, first this parameter for a test.

7.7 Control Mode Configuration (ProTuner)

The factory setting is single pulse (step & direction, or pulse & direction) control. Please modify this parameter when you need the double pulse (CW/CCW) control mode.

8. Wiring Notes

- In order to improve anti-interference performance of the drive, it is recommended to use twisted pair shield cable.
- To prevent noise incurred in PUL/DIR signal, pulse/direction signal wires and motor wires should not be tied up together. It is better to separate them by at least 10 cm; otherwise the disturbing signals generated by motor will easily disturb pulse direction signals, causing motor position error, system instability and other failures.
- If only one power supply serves multiple EM882S drives, separately connecting the drives to the power supply is recommended instead of daisy-chaining.
- It is prohibited to pull and plug connector P3&P4 while the drive is powered ON, because there is high current

flowing through motor coils (even when motor is at standstill). Pulling or plugging connector P4 with power on will cause extremely high back-EMF voltage surge, which may damage the drive.

9. Typical Connection

A complete stepping system should include stepping motor, stepping drive, power supply and controller (pulse generator). A typical connection is shown as figure 12.

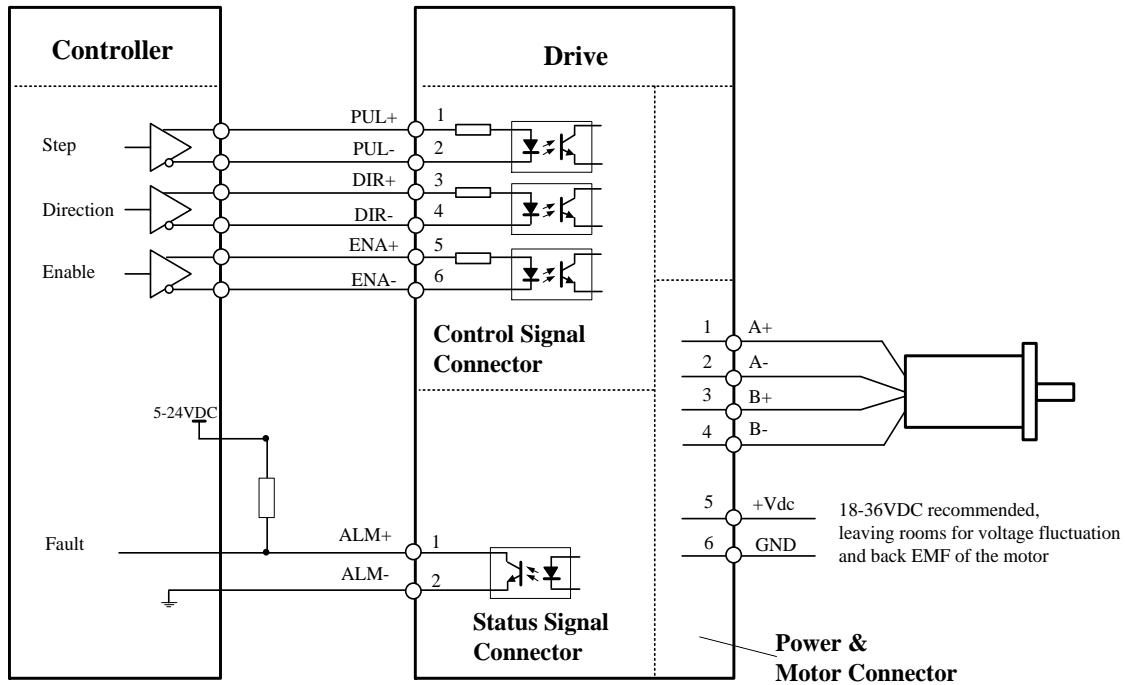

Figure 12 Typical connection

10. Sequence Chart of Control Signals

In order to avoid some fault operations and deviations, PUL, DIR and ENA should abide by some rules, shown as following diagram:

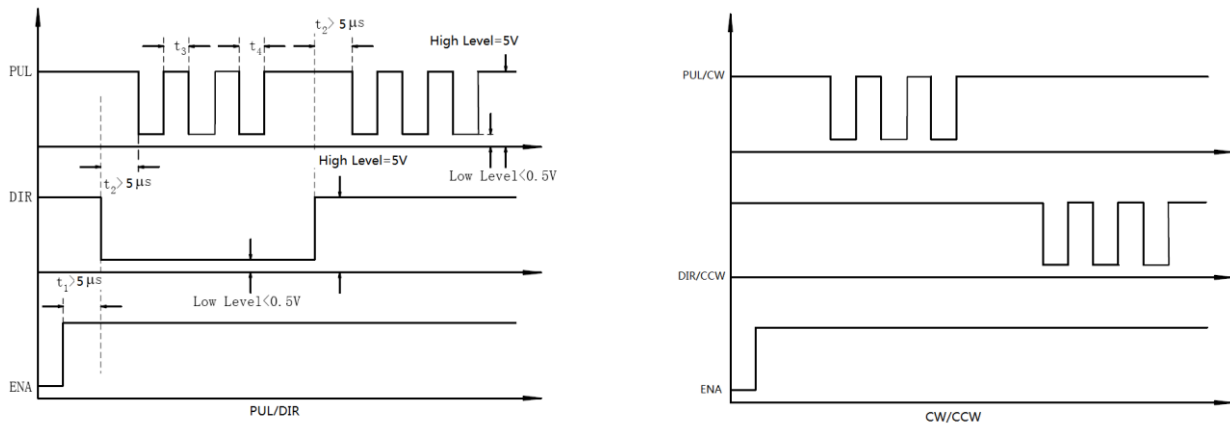

Figure 13 Sequence chart of control signals

Remark:

- a) t_1 : ENA must be ahead of DIR by at least $5 \mu s$. Usually, ENA+ and ENA- are NC (not connected). See

“Connector P1 Configurations” for more information.

- b) t_2 : DIR must be ahead of PUL effective edge by $5\mu\text{s}$ to ensure correct direction;
- c) t_3 : Pulse width not less than $2.5\mu\text{s}$, duty cycle recommend 50%
- d) t_4 : Low level width not less than $2.5\mu\text{s}$

11. Protection Functions

EM882S incorporates are built with over-voltage and over-current error protections. When it is under error protection, the red LED light will blink for 1 or 2 or 4 times in a period of 3 seconds. If fault output connection is connected, the impedance mode between ALM+ and ALM- will be changed (See “Fault Output Configuration” section for detail).





Priority	Time(s) of Blink	Sequence wave of red LED	Description
1 st	Always on		The drive was short-circuited or burned out.
1 st	1		Over-current protection activated when peak current exceeds the limit.
2 nd	2		Over-voltage protection activated when drive working voltage is greater than 90VDC
3 rd	5		Motor stall protection

Figure 14 Error Protections

When above protections are activated, the motor shaft will be free or the red LED blinks. Reset the drive by restart it to make it function properly after removing above problems.

12. Troubleshooting

In the event that your drive doesn't operate properly, the first step is to identify whether the problem is electrical or mechanical in nature. The next step is to isolate the system component that is causing the problem. As part of this process you may have to disconnect the individual components that make up your system and verify that they operate independently. It is important to document each step in the troubleshooting process. You may need this documentation to refer back to at a later date, and these details will greatly assist our Technical Support staff in determining the problem should you need assistance.

Many of the problems that affect motion control systems can be traced to electrical noise, controller software errors, or mistake in wiring.

Problem Symptoms and Possible Causes

Trouble	Solution Measures
Motor is not rotating	No power, to start power supply
	Pulse/revolution setting is wrong
	DIP switch current setting is wrong
	Fault condition exists or the drive is disabled
Motor rotates in the wrong direction	Motor phases may be connected in reverse
	Pulse mode may be wrong
Red light blinking	Red light blinks 1 time or always on, try not to connect the motor and restart the power supply
	Red light blinks 2 times, check the power voltage and restart the power supply
	Red light blink 5 times means motor stall
Erratic motor motion	Current setting is too small, losing steps
	Wrong motor connection or has broken circuit in motor coil.
	The current of the control signals is not in the range of 7-15mA
	Control signals don't meet the requirements of chapter 10 , check the waveform of the control signals
Motor stalls or loss steps	Output current of the drive is too small or motor torque is not enough
	Acceleration is set too high
	Power supply voltage too low
	Modify the activated edge value in the ProTuner or the control signal is interfered with.
Excessive motor and drive heating	Inadequate heat sinking / cooling
	Automatic current reduction function not being utilized
	Reduce output current

13. Warranty

TWELVE MONTH LIMITED WARRANTY

Motion Control Products Ltd warrants its products against defects in materials and workmanship for a period of 12 months from the shipping/purchasing date. During the warranty period Motion Control Products, at their discretion, will repair or replace products that are proved to be defective.

EXCLUSIONS

The above warranty shall not apply to defects resulting from: improper or inadequate handling by the customer; improper or inadequate customer wiring; unauthorised modification or misuse; or operation beyond the electrical specifications of the product and/or operation beyond environmental specifications for the product.

SHIPPING FAILED PRODUCT & OBTAINING WARRANTY SERVICE

If your product should fail during the warranty and you want to obtain warranty service, a RMA (returned material authorisation number) request form must be filled in on our website <https://www.motioncontrolproducts.co.uk/returns/> before returning the product for service. Please include a written description of the problem along with contact name and address. Customer shall prepay shipping charges returned to Motion Control Products for warranty service, and Motion Control Products shall pay for return of products to the customer, providing the fault is not customer caused. Send the failed product to your distributor for your area or to **Motion Control Products Limited**, 11-15 Francis Avenue, Bournemouth, Dorset BH11 8NX, UK. Also enclose information regarding the circumstances prior to the product failure. For full terms and conditions of Warranty and Returns Policy, please refer to our website <https://www.motioncontrolproducts.co.uk/returns/>

WARRANTY LIMITATIONS

Motion Control Products makes no other warranty, either expressed or implied, with respect to the product. Motion Control Products specifically disclaims the implied warranties for a particular purpose. Some jurisdictions do not allow limitations on how long the implied warranty lasts, so the above limitation or exclusion may not apply to you. However, any implied warranty is limited to the 12-month duration of this written warranty.